



# A Survey of Medium Access Control Protocols for Unmanned Aerial Vehicle (UAV) Networks

Jyoti

School of Computer Applications, Lovely Professional University, Phagwara, Punjab, India.  
dhanjujyoti1080@gmail.com

Ranbir Singh Batth

School of Computer Science and Engineering, Lovely Professional University, Phagwara, Punjab, India.  
ranbir.21123@lpu.co.in

Sahil Vashisht

Department of Computer Science and Engineering, Faculty of Engineering & Technology, SGT University, Haryana, India.  
sahil\_feat@sgtuniversity.org

Received: 30 March 2021 / Revised: 17 May 2021 / Accepted: 14 June 2021 / Published: 28 June 2021

**Abstract – The use of Unmanned Aerial Vehicles is growing increasingly across many civil benefits, including real-time monitoring, medical emergencies, surveillance, and defence. Many different types of UAVs are being developed to meet the demands of diverse users. Therefore, the research areas in the UAV domain are evolving as the types and number of UAVs increase. UAV's faces numerous problems in channel accessing, radio allotment, latency and most of these issues are because of the ineffective MAC protocols, moreover MAC is also important because it affects not only the system performance but also the energy efficiency in battery-powered sensor nodes. In this research article various Medium access control (MAC) protocols discussed and qualitatively compared on the basis of various Quality-of-Service (QoS) parameters.**

**Index Terms – Unmanned Aerial Vehicles (UAV), Medium Access Control (MAC) Protocols, Antennas, QoS, Architecture.**

## 1. INTRODUCTION

The use of Unmanned Aerial Vehicles (UAVs) has steadily grown over the last decade. It has now become a generic analysis method for collecting photos and other demand-based data from a geographic area of interest. New networking protocols and technologies have to implement in the epoch (exam grid and cloud computing, large-scale data analytics, and networking identified by software). UAVs are used exponentially in many fields of civil activities, remote sensing, real-time traffic surveillance, science and rescue, cellular coverage, delivery of goods, protection and tracking, agricultural precision, and civil infrastructure inspections. The next major revolution in smart UAV technology promises to deliver new possibilities, especially for civil infrastructure, for a range of applications about risk reduction and lower costs.

Survey facilities output requirements, network applications project criteria, information standards, and minimum network communication data for civil operation. The top speed in some programs is 10 hours a day, and they can cross 400 km/hr [1,2]. The usability of these flying vehicles in logistics has also seen a rise. A UAV is also able to deliver hot pizzas. The biggest pizza chain in the world, Domino, has successfully distributed pizzas by drones to its customers for the first time in the industry. In comparison, the online trader Amazon dispatch in December 2016 air drones much quicker [3]. UAV's testing in an emergency has begun by the United Package Service through UAV certification as a daily supply alternative to follow. DHL, the world's largest company, has started shipping products and logistics with UAVs. In comparison, many start-ups who use UAVs for business operations make this best known to the people by launching UAVs. UAVs put our everyday lives on case photos, such as wedding video camera shots, coverage of sporting events, and the use of journalism. Also, Google Loon and Facebook investigate the work of multi-UAV systems in developed countries and remote areas to provide internet services. The use of networking in emergency scenarios, such as a high degree of manoeuvrability, low acquisition, broad coverage, and fast deployment of airbase and airborne network relays, has also become more relevant.

Figure 1 indicates the exponential growth of UAVs for deployment according to the FAA aerospace prediction estimate (2016–2020). 5,42,500 drones projected to be float in the skies of America by 2021, according to the report. Concretely, the forecasted UAV demand of 2022 will amount to approximately \$28.27Billion, with CAGR 58 as a base year

**SURVEY ARTICLE**

accounting for 13.51% in 2016. The numbers and functionality of UAVs are expected to increase dramatically after the above information to be revised. Such statistics and facts draw the investigator to find out more UAVs. In several recent studies, the ability and reduced size of microelectronic devices have also been shown as key factors behind the production of these autopilot and UAV applications in real-time. They classified the UAV's by weight, altitude, and range that as shown in table 3. Table 1 shows the abbreviation table.

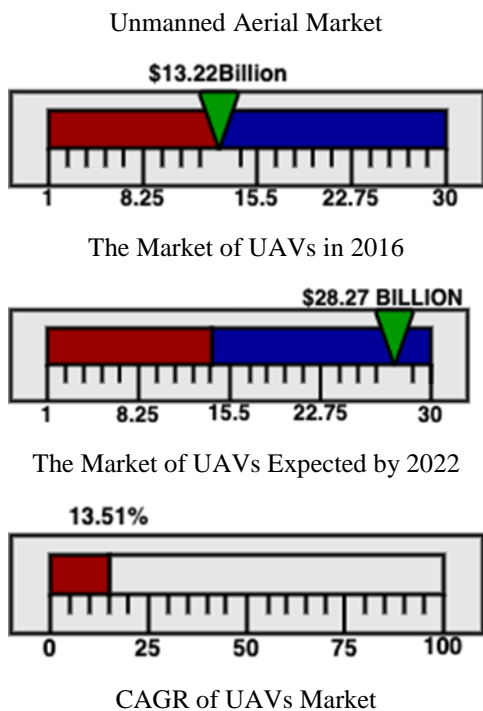

Figure 1 Reports on Airspace Forecasts Showing Current Market Trends

Abbreviation	Meaning
MAC	Medium Access Protocol
DHL	Prominent Courier Service
CAGR	Compound Annual Growth Rate
FAA	Federal Aviation Administration
QoS	Quality of Service
FANET	Flying Ad-hoc Network
MANET	Mobile Ad-hoc Network
VANET	Vehicular Ad-hoc Network
VGPS	Global Positioning System
WPA	Wi-fi Protected Access
SSID	Service Set Identifier
RTS	Request to Send
CTS	Clear to Send

ACK	Acknowledgement
VCPS	Vehicular Cyber Physical System
IoD	Internet of Drones
GCS	Ground Control System
LOS	Line of Sight
BLOS	Beyond Line of System
SAR	Search and Rescue
DoS	Daniel of Service
GPS	Global Positioning System
CCS	Centralized Communication System
TDMA	Time Division Multiple Access
CSMA/CA	Carrier Sensing Multiple Access/ Collision Avoidance
DCF	Distributed Coordinated Function
DIFS	DCF Interframe Spacing
NAV	Network Allocation Vector
BEB	Binary Exponential Backoff
RF	Radio Frequency
SoI	Signal of Internet
DRTS	Directional Request to Send
HoL	Head of Line
FIFO	First in First Out
IMU	Inertial Measurement Unit
PHY	Physical
SIFS	Short Inter Frame Spacing
NL	Neighbour List
CSI	Channel State Information
LV	Location Vector
BTS	Busy to Send
CCH	Control Channel
SCH	Service Channel
CCHI	Control Channel Intervals
MRC	Maximum Ratio Combining

Table 1 Abbreviation Table

	MANET	VANET	UAV Network
Description	In an ad-hoc way, mobile Wireless nodes communicate with other nodes within communication range. (There is no need for a centralized infrastructure).	Vehicles serve as mobile nodes in ad hoc networks. Vehicles communicate with one another and with the roadside unit.	Airborne node network that is ad hoc or infrastructure-based. UAV-to-UAV connectivity as well as communication with the control station.

**SURVEY ARTICLE**

Mobility	Slow the average speed of 2m/sec. At some famous locations, random movement with varying densities is more common.	High-speed travel is usually 20-30 m/s on highways and 6-10 m/s in cities. Road layout, traffic and traffic laws restrict the amount of predictability.	Speed varies from 0 to 100 m/s in most situations. Movement may be in two or three dimensions, and is typically regulated by the task.
Topology	Random Ad-hoc	Star with infrastructure and ad-hoc among vehicles.	Star with control, ad-hoc/mesh among UAV's.
Topology Changes	Dynamic-nodes join and leave unpredictably network prone to partitioning.	More complex than the MANET'S. Linear flow. Common partitioning.	Stationary, slow or quick. It can be flown in managed swarms. The network is vulnerable to partitioning.
Energy Constraints	A battery powers most nodes, so the energy needs to be conserved.	Car batteries or their own batteries can power devices.	Limited energy for small UAVs. Weight and flying time are affected by the battery.
Typical use cases in public and civil domains	Information distribution (emergencies, advertising, shopping, events) internet hotspots.	Traffic & weather info, emergency warnings, location-based, infotainment	Rescue operation, agriculture crop survey, wildlife search, surveillance.

Table 2 Different Ad-Hoc Networks Comparison

This detailed UAV categorization user finds a compatible UAV accordingly. The production and use of small UAVs eliminate all operations and failure rates instead of a single high-cost UAV. It also offers additional infrastructure and faults-prone installations. To carry out comprehensive operations, the mission controllers must be aware of the current situation for the UAV and the base station. The utility

of aircraft needs the high-end network support required to ensure improved service efficiency (QoS). A Flying Ad Hoc Network (FANET) [4,5] is derived from two-parent networks to establish high-performance data communication and to monitor self-sustaining movements between UAVs for example, MANET, and VANET. The table 2 explains the aspects that differentiate this from other ad hoc networks. Topology shifts in UAV networks may be much more common. Some UAVs may lose all of their strength and need to reload the information. UAVs may be out of the network and fail because the nodes change position, links may form and disappear the UAV's relativity can differ. The density of nodes in many implementations the best transmission strategy. In small UAV networks, energy limitations are much broader. Power could be on from the automobile battery in the automotive networks that helps in charging when the car is on track. The nodes (smartphones, laptops) in handheld ad-hoc networks, too. Power supplies are commonly accessible for many hours. Typically small UAVs should provide ample power for a 30-minute flight. Firstly the transmitted signal is lower power. Second, the connections are intermittent due to the floating or dying of power-drained UAVs. Node dynamics will cause the network to coordinate and reorganize, introducing the particular criteria for routing. For the stabilization of the UAV network [6], the routing Protocols must use resources effectively.

1.1. The Challenges of UAV Networks

Before the successful use of UAVs to include secure and efficient context-specific networks, there are several problems to overcome. It is too difficult to develop and sustain successful contact between UAVs we will see later, though offering improved capacity and capability.

The problems which need to address are present in all the participants of the UAV communication network. The number of nodes and contacts in UAV networks varies, as they do in most wireless networks, and nodes change their relative locations. Depending on the program, UAVs can travel at different speeds so that connections have form intermittently. What are the difficulties of such conduct? Firstly, such elements may not have been intuitive in architectural design. The topology of the fluid nodes vanishing/finishing links all challenges the designer to go deeper than usual ad-hoc grids. Secondly, a constructive or reactive scheme may not be easily introducing in the routing protocols. When UAVs crash, Several times, the inter-UAV backbone must be reorganizing. In some cases, the networks could split, and challenges would be to route packets from a source to a destination while perfecting the dimensions selected [46]. The third task will be to hold user meetings by transferring them from a non-service UAV to an operational UAV effortlessly. Finally, ways to save electricity from power-hungry UAVs need to improve network life.

**SURVEY ARTICLE**

UAV,s Categories	UAV's Type	Weight (in Kg)	UAV's Application	Flight Altitude in (M)	Range (in KM)	Characteristics
Rotary Wings	Nano	< 0.025	Logistic	100	<1	Easy to Use
	Micro.	< 5	Monitoring & data collection	250	<10	Can hover in a restricted area
	Mini	< 30	Aerial Photography	150 to 300	<10	Example: Quadcopter
Fixed Wings	Close Range	150	Search & Target Decoy	3000	10 to 30	Fast flight range
	Short Range	200	Aerial Mapping	3000	30 to 70	Good camera control
	Medium Range	1250	Oil Pipeline inspection	5000	70 to 200	More extensive area coverage
Low altitude platform	Low Altitude deep penetration (LADP)	350	Coverage & capacity Enhancement	50 to 9000	>250	Flexible and quick deployment
	Low Altitude Long Endurance (LALE)	<30	Intelligence and surveillance	3000	>500	Can hover up to hours
High altitude platform	Medium & High Altitude long Endurance	1500	Environment and weather monitoring	17000	>500	Very long endurance

Table 3 Categorization of UAVs Based on Type, Weight, Applications, Altitude, Range, and Characteristics

**2. RELATED WORK**

Sahil vashisht et. al,[1] addressed the MAC protocols in two groups, focused on both directional and omnidirectional antennas. The author also addresses emerging industry dynamics and stresses the UAV use cases across various technology and norms. Different design requirements and facets of MAC design are detailed. Hayat et. al, [7] described from a networking and coordination point of view the visioning of civil applications and specifications of UAV networks. However, in this survey, simulation of the platform and channel access structures in UAV networks was not explicitly considered. Gupta et.al, [8] surveyed to simulation case study during a discussion of attack phases and their protocols and addressing coagulation assaults such as UAV freezers, waypoint shifts, forced clustering, and UAV cells secrete. Sharma et. al, [9] studied the various adhoc networks by researching the formation of the cooperative network. To strengthen the application of UAV networks, the cooperative structure and models of structured workability of two distinct networks were reviewed.

Mukherjee et. al,[10] conducted a survey for FANETs on different communication and routing protocol architecture problems has been carried out. Fotouhi et. al, conducted a survey[11] on UAV wireless connectivity studies are carried

out using UAVs in cellular communication to determine the threats and opportunities. UAV relays. He et. al,[12] addressed the specifications of a stable and effective UAV communication infrastructure. Communications protection has been emphasized and security countermeasures, a global positioning system (GPS), and the IEEE 802.11 wireless threats have been addressed. Wireless attacks are discussed. Also, the authors addressed the specifications of a stable and effective UAV communication infrastructure. Qiao et. al, proposed DJI Phantom 4 system [13] concentrated on the identification of spoofing by vision sensors in the area of protection attacks. The authors investigated the proposed DJI Phantom 4 system. Dey et al, [14] proposed a few countermeasures against Wi-Fi encryption (WPA), Telnet Secret, MAC, and Concealed Service Identifier attacks (SSID). Concentrated on the drone design and operating overview and identified attacks and weaknesses associated with their activities. DJI Phantom 4 and Parrot Bebop 2 drones have been targeted due to vulnerabilities.

Daneil et.al, [15] proposed the Centralized Intelligent Channel Assigned Multiple Access (C-ICAMA) was seen in hierarchical, heterogeneous multi-layer ad hoc wireless networks. The C-ICAMA is a smart planning algorithm for the protocol on contention reservations. In this heterogeneous multilayer environment, the bandwidth ratio of an up-link to a

**SURVEY ARTICLE**

down-link can be modified dynamically to match rather asymmetrical data traffic. The AMUAV has been introduced by Abdel et.al,[16] and it has the capacity to change the UAV directional antenna and other specifications. They find that the new scheme would increase the network efficiency by integrating the antenna system directionality with external parameters. Bekmezci et al.[17] Proposed differences of mobility, node density, shift in the topology, radio transmission, energy usage, computer power and localization between FANET, MANET and VANET and ad hoc networks. FANET layout factors, such as latency, adaptability, bandwidth, scalability, and UAV platform limitations are also explored. Discuss open science problems for FANETs, as well as cross-layer designs. Choudhury et al. [18] suggested a MAC protocol using directional antennas features. It can be used for the connection of multi-hop RTS nodes with a single Hop to transmit ACK, CTS, and DATA. The findings suggest that the MAC protocol is superior to IEEE 802.11, but the result focuses on the topological structure and flow patterns of the system. Anish et al.[19] Proposed a SeDaTiVe approach for software-defined networking that uses a profound learning architecture in order to track incoming traffic in the network in the VCPS sense. The benefits of deep training in the control of network traffic are that it learns the secret patterns in data packets and offers an optimal form of learning.

M. Singh et al,[20] described architecture provides the blockchain with a low overhead, while making the ecosystem immune to several security problems. The idea of a lightweight blockchain platform for secure data distribution within the IoD ecosystem was proposed. The. S. Vashisht et al,[21] surveyed on strategy to recommended for optimum media access control, which also discusses the energy requirements, along with the role of any drone in a network, to avoid potential network failure. Cao. et al,[22] proposed a comprehensive remote relay selection by optimizing the broadcast protocol for exponent partitioning to ensure the optimal message transmitting speed of the general scenarios and a reasonable diffusion speed in the negative scenario. S. Garg et al,[23] Suggested the Multi-UAV Vulnerability Research tree-based attack-defense architecture. An attack-defense tree depicts any pass of the defender to the tactics of the attacker. J. Wang et al,[24] Introduced an energy-efficient routing system together with technology for clustering and sink versatility.

B. Yang et al.[25] The author suggested two successful D2D under laid UAV network architectures, in which each UAV functions as a flying BS or an aerial UE. Then, the author purposed a covert coordination technique that combines mode selection and cooperative jamming, where mode selection enables each user device to adaptively transform between half-duplex and full-duplex communication modes, and cooperative jamming ensures that idle D2D pairs inject

interference to confuse adversaries. C. -H. Liu et.al [26] The author investigated a 3D point method whose representations had made up of a 2D homogeneous PPP, with altitudes being the markings of the 2D homogeneous PPP. The fundamental properties of the proposed 3D point method they investigated for the APIL and APDL scenarios, and pave the way for a tractable analysis of the downlink coverage of a UAV-enabled cellular network modelled by the proposed 3D point process. D. -H. Tran et.al,[27] Proposed the reducing overall energy usage by UAVs while maintaining contact with the ground base station. Two algorithms had used to plan the UAV trajectory. The first algorithm employs a heuristic approach, while the second employs dynamic programming. As a traveling salesman dilemma, connectivity specifications formulated. The suggested protocol reduces the likelihood of outages and consumes fewer resources, according to the results.

### 3. ARCHITECTURE OF UAV

The Civilian UAV system consists of three main elements: the aircraft, the GCS, and the communication data link. Architecture of UAV described about various components in which the aircraft consists of a airframe the ground control system that is the controller of the flight and the exchange of data. Our analysis only concentrates on the components which are essential to our research and believes the collection of sensors, actuators, and flight controllers. Figure 2 describes architecture of a UAV system and its main elements [28].

#### 3.1. Controller of the Flight

The control unit is the drone's central processing device. In addition to drone phase stabilization, it reads sensor data, analyses it for useful information, and transmitting the information to the GCS according to the method of control, or the actuator control units directly feed into the modified condition. The flight controller uses a specific form of communicating with the GCS. Most specifically, the flight controller manages the GCS instructions that effect influence the control units in use.

The flight controls have several channels linked to the telemetric signals that can send to the GCS. Multiple on-board sensors or an external sensor array may be attached to the control system. UAVs Gyroscope, a global positioning system (GPS), accelerometer, infrared camera, and magnetic orientation detector are used for interface sensors.

#### 3.2. Ground Control Unit

To track or control UAVs, a ground-level control station provides operations for human operators. The size of the GCS varies depending on the drone model and purpose. In other words, GCSs are simple to use, manual transmitters used by professionals in mini-and micro-drown entertainment, the separate facility with many workstations used as the GCS for

**SURVEY ARTICLE**

tactical and strategic drones. A GCS links a drone via a wireless link to transmit commands and receive data in real-time to create a virtual capability.

3.3. Links to Data

The data link relates to the wireless connection between the drone and the GCS to provide control information. The

contact relation followed differs according to the context of UAV operations. LOS missions, where control signals can be sent and received by direct radio waves outside the spectrum, are divided into BLOS missions, depending on their distance from the GCS. The drone, an aircraft itself, is operated by satellite communications or by a relay aircraft. The mission can be conveying through direct radio waves.

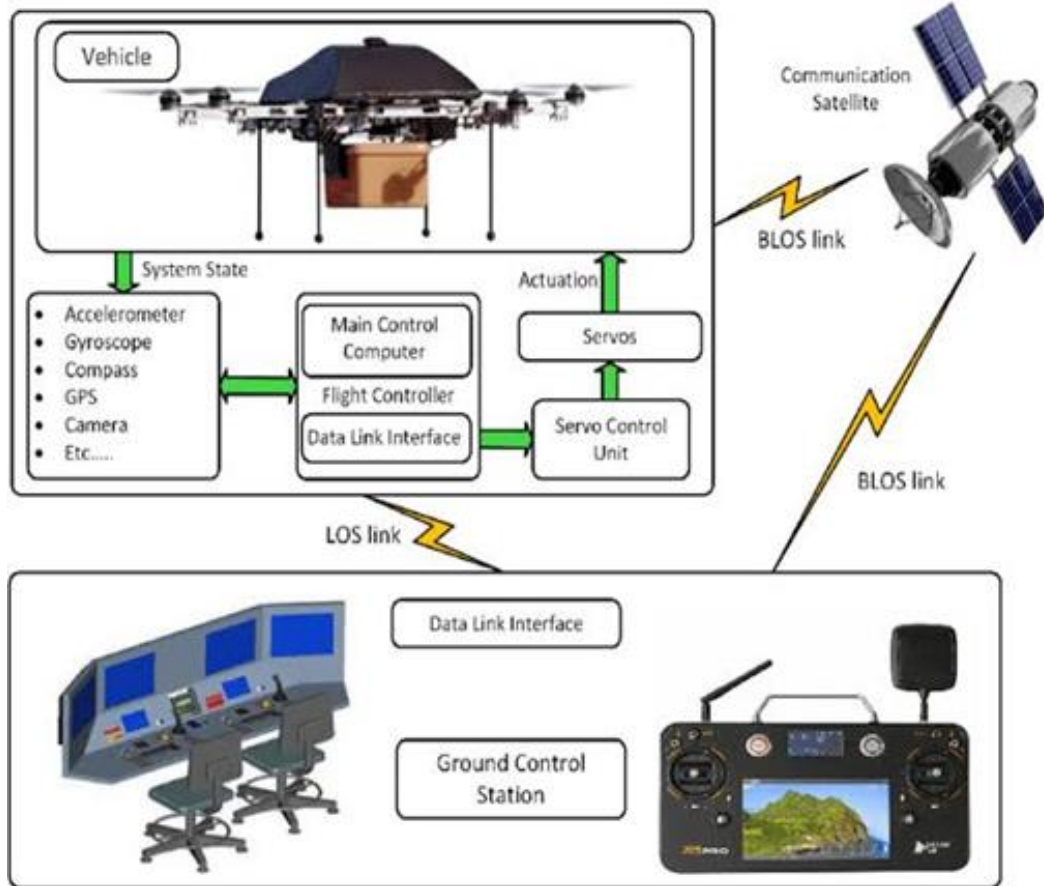

Figure 2 Architecture of UAV

3.4. Connection Issues in UAV Networks

Sometimes changing topological conditions demand a secure relation between multi UAVs. However, that something you want to handle to ensure effective data transfers without interrupting the user. The high degree of mobility and someone currently underway. Moreover, the redesigning of the current MAC protocols needs many connectivity difficulties. A few of the following listed as challenges [29].

3.4.1. Bandwidth

Bandwidth availability is most important for UAV operations for secure networks and fast data speeds. Bandwidth connectivity applications such as live video, mapping, traffic control, and SAR real-time and continuous bandwidth support the UAVs. Furthermore, such implementations necessitate the

use of a separate and adequate air quality band. As a result, UAVs share the same bandwidth as commercial and military aircraft.

3.4.2. Failure on One Point

A single means of information transmission will interrupt the strengthening of activities and the decline in overall production. UAV has shown that it is preferable to focus on a single knowledge-building method. The failure of the system may lead to failing the whole operation.

3.4.3. Scalability

As each network is signify to be a highly scalable most critical problem of a network is scalability. For UAVs, as a node joins or exits the cluster, networks can be commended

**SURVEY ARTICLE**

and afforded technically for a network to scale. However, the specifications for both topology and width new node added it affects. Algorithms are required for UAV networks to allow for high scalability and low-performance degradation protocols.

3.4.4. Safety

UAVs can navigate and fly anywhere at any time, this feature raises lots of issues about their safety and privacy in non-flying areas. Moreover, attackers or intruders can rapidly hack and hijack these flying equipment. In the vicinity of Empire state buildings and nuclear power plants, many reports of UAV accidents reported in recent times requiring stringent specifications, continuous monitoring, and regulations. In the hands of reckless hackers, the UAVs are totally under power who use the GCS data link or GPS signal spoofing. Therefore, safe communication between intra- and inter-UAV transmissions is urgently necessary.

3.4.5. Reliability

The network is supposed to be more secure as it is often vulnerable to a range of network attacks. These attacks will impair the UAV data's functionality and privacy. In the past few incidents, including spoofing of data connections, DoS attacks, Ping of the Death, SYN Flood, and many more have been reporting. The architecture of the UAV network should be defective, reliable, and safe.

3.4.6. Data Congestion

For real-time information processing, all UAVs linked to GCS in CCS, which can create data congestion problems in CCS. Further, upstream and downstream GCS data would be blocked. Apart from that, it goes beyond the issue of latency and end-to-end delay [47].

3.4.7. End to End Delay

The sudden improvement in UAV mobility models and data transmission from multi-hops allows packet distribution is too delayed. Doppler effects, frequent adjustments in the touch scale, and wireless transmission performance are among the many influences that affect communications. Besides, it is important for specific to secure applications, to deliver packets within a limited period in this network.

3.4.8. Latency

The retardation of the network to a certain extent may have catastrophic impacts. The UAV latency criterion depends on applications such as crop and border monitoring and traffic surveillance.

**4. PROTOCOLS OF THE MAC**

The UAV MAC protocol is significant by its ability to systematize the distribution of the minimal available media.

UAVs are not crashing at the receptor site and monitor all physical layer access reliably the MAC protocols come into service and the node is enabled to transfer the packets. MAC protocols can help control and coordinate communications to multiple node channels so that data can be pass through a single node if all nodes in a network use the same physical route. When it comes to getting the most out of limited tools, choosing the correct antenna to relay on data is always critical. A concise analysis of the types of antennas used for UAV communications is present to provide more information on the antennas.

The challenge is connecting to the terrestrial network infrastructure for multiple UAV systems, especially when wireless connections span hundreds of kilometers. Long-distance cellular technology networking communications lead to significant transmission delays in which high-speed networks cannot ignore. Protocols of medium access control that allow for single-packet channel transmission do not benefit from propagation delays. As the spread delay increases, it results in low usage and a low degree of service efficiency. The vulnerability of competing protocols, the signal collision reveals the effect of retransmissions on the efficiency of the Network. Time-Division Multiple Access (TDMA) and its variants are not acceptable as pure reservation scheduling methods since complex topology to intermittent UAV transmission can lead to wastage of resources. Thus it is necessary to develop a suitable medium access control (MAC) scheme to provide propagation delay to boost network efficiency in the communication between UAVs and the infrastructure.

4.1. MAC Protocol Architecture

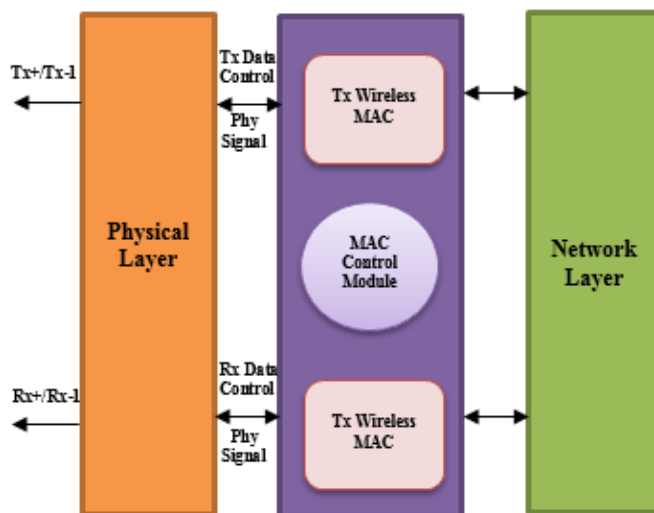

Figure 3 Architecture of MAC Protocol for Wireless Network

Figure 3 presents the MAC's basic architecture for wireless communications. Specifically, ad-hoc MAC wireless network

**SURVEY ARTICLE**

protocols can be applying to the UAVs category according to Path Access Methods, i.e. Free Contention Access methods & Random Access Methods. Nodes contend with each other for a certain amount of time in contentious methods for obtaining access to a medium. Other nodes are silent and throughout this time, when they are continuously scanning for the channel and Considering that only when there is no collision and the data transmitted to the destination node [30].

Collision Avoidance [31] (CSMA / CA) carrier sense multiple access is the most common mechanism used to avoid the collision in the controversial process. On the opposite, the nodes are delegating to the pre-decided schedule in non-contention-free methods that are not complete to access the channel. Although, propagation delays and scalability problems are present in this scheme. The Common Carrier Sense Multiple Access (CSMA) MAC process is the enhancements that have been implementing for wired networks such as CSMA/CD collision detection, which cannot be used directly on wireless networks.

A backdoor/re-scheduling method for network collisions or running channels is the primary distinction between DCF and CSMA. Virtual and Physical sensing are using for every DCF MAC protocol node for IEEE 802.11. The node postpones its DCF interframe spacing (DIFS) transmission for its packet transmission if the channel is idle and the NAV is not setup. However, the node selects a random interval  $[0, CW]$  when the channel is busy and the amount of time before the channel is connected. At first, a minimum value ( $CW_{min}$ ) define in the Contention Window ( $CW_{Min}$ ). The sum of the backoff counter is decreased by one for every idle moment. The counter is awaiting zero in any node and the packets that can send to the node [32]. However, the (BEB) algorithm is up, and packet re-transmission starts when there is a crash. After each collision, the CW value is doubled in this BEB algorithm until the maximum contention window ( $C_{max}$ ) is reached. The packet is discarding after meeting a retrieval threshold. In addition, the nodes freeze until the channel begins to feel perfect for DIFS duration before the node gets busy, CW is to set its value ( $CW_{min}$ ) for future transmissions when the packet is transmitted successfully.

#### 4.2. Type and Bases of Antenna

Converting electrical signals into electromagnetic waves is the primary function of the antenna. As seen in Figure 4, the two primary modes for control of a directional antenna. In such a way, these omnidirectional antennas are usually modelled and emit an equal number of signals in each direction. On the opposite, by focusing on one and more directions they can radiate the directional antennas in the angular direction. The main features of the antenna are its gain by calculating the performance and orientation of the antenna. In comparison to the omnidirectional antenna, the antenna gain determines the relative power in a direction [33].

##### 4.2.1. Omni-Directional Antennas

Radiofrequency (RF) radiation is also intercepting in the horizontal direction, 2D geometrical plane following the isotropic shape of an omnidirectional antenna. Such antenna forms are appropriate for the simple RF habitat if no prior user directions information is needed or obtainable. However, the intended user receives only a share of the total potential in this unfocused process. As a result, a considerable majority of the transmitting signal energy is transmitted in both directions when using an antenna, the intended path of using a significant amount of radio energy is waste.

Moreover, their broadcast capacity has been improving to address the environmental obstacles of omnidirectional antennas. Consequently, the signals absent from the intended recipient conflict with other contiguous cells or users. But it is not judiciously possible to decline the signals interfering with communicating users with the single element data transfer method. It also prevents spatial reuse, reuse frequency, and transmission of packets.

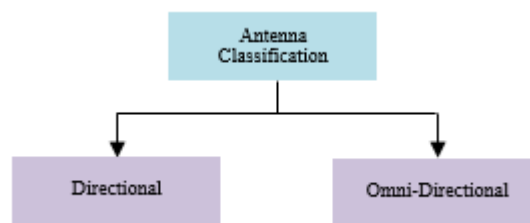

Figure 4 Classification of Antenna

##### 4.2.2. Directional Antennas

The need for geographic reuse, improved transmission speeds, and more coverage is quick as the numbers of wireless networks are growing. To prioritize these criteria, the signal communications within these networks rely on beam widths that are short. The value of limited beam widths is that which helps the radio signal to be target more directly. Moreover, the rate of propagation, coverage, and spatial reuse has improved gradually. In comparison, the rate of propagation coverage and spatial reuse dynamically improve. The direction with the highest gain is known as the boresight direction in these antennas. There is a lot better advantage in the boresight directions in directional antennas than in omnidirectional antenna [34]. The directional antennas are codified in adaptive antennas and switched beams, as shown in Figure 5.

###### 4.2.2.1. Switched Beams Antenna

Shifting beam antennas are less difficult for conventional Wi-Fi networks. This system is fixed beams and increases the radiation pattern in the direction at the antenna location. For an individual, each beam can use as a distinct field. The system also uses shifting technologies that allow mobile



**SURVEY ARTICLE**

devices depending on the maximum signal power to pick a pattern from predefined patterns. The key aim of the beam antennas is to maximize the benefit from the consumer but scalloping doesn't guarantee maximum profit. However, the beam may operate to changes in signal phase differences in different directions. Moreover, a lack of power over intrusion in multi pathways renders it unsuitable for extremely responsive application networks [35].

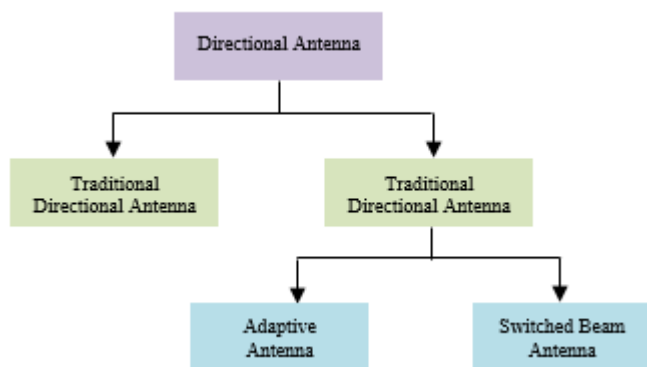

Figure 5 Classification of Directional Antennas

4.2.2.2. Adaptive Antennas

The maximum gain and some little gain side and back-lobes are the flexible directional array configuration. A beam width also characterizes the Directional antenna emission pattern. The antenna's beam diameter is the angle of each side of the boom and is half the entire gain. The antenna's main lobe, providing full constant antenna power, is the Key pattern radiation beam. As the lobe is guiding to the attention (SoI) contributes to increasing the freedom area in which 3DB of the primary lobe spike is more clearly than defined as the main beam. These signals are using to increases the receiving amplitude by subduction of the antennas using signal treatment algorithms. Besides, these antennas will provide the respective individual with a personalized radiation pattern. Smart antennas deliver substantial gains over conventional antennas in low interferences. However, when high interference is detected, the adaptive antennas work better than the standard or switched beam antenna.

**5. DIFFICULTIES IN ADOPTING THE UAV NETWORK MAC PROTOCOLS**

According to recent studies, using standard MAC protocols designed for general ad-hoc networks is not recommended for UAV networks. Since the MAC protocol designs are complicated by time develop transmission features of the UAV network increased complexity and dispersed MAC restrictions. For MAC protocols, the need for UAV networks such as local knowledge and energy efficiency raises critical challenges. Below are some of the problems involved with the deployment of Omnidirectional and directional antennas in UAV networks.

5.1. MAC Layer Problems in UAVs Networks Using Omni-Directional Antennas

Numerous studies have been doing in the past on the use of omnidirectional antennas in UAV networks. As antennas that receive/distribute energy to both directions equally. Both adjacent nodes are surrounding to interaction blocking the participating nodes during the transmission to avoid collisions [36]. But if UAVs use such antennas after problems occur:-

5.1.1. The Short-Range of Transmissions

That is the biggest downside of using this network UAV isotropic antennas, and it transmits the doughnut-shaped signals. That limits the antenna's range of propagation for a specific diameter only. Only a receiver can communicate because an antenna's receiving diameter is less than its transmitting diameter.

5.1.2. Energy Consumption

Regular signal propagation in both directions requires significant resources, and no recipient is present at the other end. However, other pending messages may also be reviewed or monitored. For UAV's a crucial operation may be failing the consumption of the extra bit of electricity. Besides, the node moves to an optimal state after looking for a transmitter for a bit. A significant amount of energy is needed to get this node back into contact mode. The energy management in the UAVs is thus additionally burdened.

5.1.3. Limited Capacity for the Network

The capability of the network has based on the probability of a complete range of competitive communications. These antennas are limited to linking a broad number of users or nodes to discourage collision and interruption. In the reciprocal channel, entrance antennas don't have the correct collision prevention function.

5.1.4. Incorrect Management of Channel Access

As previously said, these antennas are unable to accommodate both access control and lateral antennas due to the absence of a collision avoidance scheme. The task of ensuring equal channel connectivity for all users is rising with a rising number of nodes connected to the omnidirectional antenna.

5.1.5. Limited Security

There is also a thoughtful protection issue regarding the potential of signals in every direction. Sometimes, the use of omnidirectional antennas is more likely to be associated with many cyber-attacks. The transmitter can't limit its access within the service radius to the abnormal intruder.

5.1.6. Low Location Awareness

Providing knowledge of the positioning of these antennas will promote functioning and working. Prior recipient position

**SURVEY ARTICLE**

couriers are available to assist with disturbance and crash reduction. It also helps to decrease power consumption gradually.

**5.2. Problems with MAC Layer Using UAV Network Directional Antennas**

Though basic MAC protocols have been developing to address the needs of the wireless medium, problems like the exposed and hidden terminal remain unresolved. The key aim is an explanation for such unresolved problems is the location-based sensing of the carrier. In particular, continuous transmission to the receiver, known as hidden nodes, can interrupt nodes outside the transmitter area within the receiver area. On the other side, both the transmitter area and receiver area known as exposed nodes. In addition, the unique characteristics of beamforming antennas must be taken into account while designing for UAV network MAC directional protocols. The problems of the beamforming protocols of the MAC antenna are considering in this section.

**5.2.1. The Issue with the Secret Terminal**

This problem happens when a node that is unknown to another continuous transmission between a few nodes attempts to link, resulting in RTS, CTS, and data frame conflicts. Due to the directional properties of beamforming antennas, two types of hidden terminal problems could find.

1. Hidden terminal because of asymmetric profit.
2. Hidden terminal because of unheard CTS/RTS.

**5.2.2. Deafness**

The deafness problem occurs when a transmitter repeatedly tries to deliver the DRTS to the intended receiver, but the receiver does not answer when the receiver moves in a different direction.

**5.2.3. Blocking of Head-of-Line (HoL)**

According to Vinay Kolar, the usage of a queuing scheme for the first-in-first-out (FIFO) MAC protocol exacerbated the issue. This phase works well for antennas with the omnidirectional, which transfer packets through a medium. However, the medium is spatially segregated and can only use for directional antennas in the intended direction. If the highest packets on the queue in a crowded path or skipped receiver nodes, the transition of any following packet will halt.

**5.2.4. The Issue with Terminal Exposure**

When two transmissions cannot carry out concurrently, even though one excludes the other, but no collision occurs, this is referring to as an exposed terminal problem. For example, in Figure6, Beams 1 and 4 are respectively communicated by A and Q. However, due to continuous directional contact

between A and Q, Beam 2 is blocked with S and beam 3 with P. However, S can try to interact with P through-beam 1, which can cause surface defects as P's beam 3 is blocked. This needless prevention leads to reduced systemic utilization and decreased concurrent delivery. That is because of the increased amount of beam-formed antenna signals that can create more knots of interference. This type of problem causes the bandwidth to be under-used because the node causes the medium to remain idle without sending packets. After all, the transmission is in the nearest area.

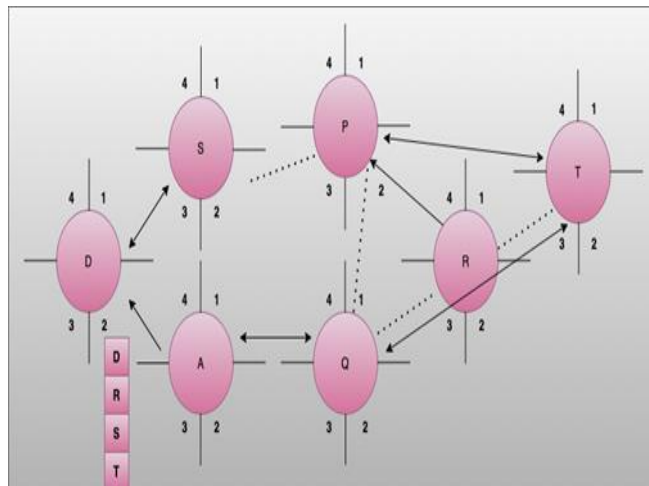

Figure 6 Different Problems in Terminal Exposure

**5.2.5. Capture MAC Layer**

Since a transmitter will forward a packet in either direction, the antenna omnidirectional inhibits the idle node. As a result, a node can listen in all directions for the request to allow the antenna to work beamformed in the required directions to receive the packet if an application is detecting from several directions. After receiving the PHY layer packet, decode nodes lead to the MAC layer of the packet. If there are no nodes assigned to the packet it is automatically discarded. That will contribute to the node wasting time to accept unwanted packets not allocated to it. A node can withhold the required packet to and from other directions from being transmitted. The retention of nodes for unproductive packets thus causes the under-use of the so-called MAC-layer capture channel.

**6. UAV NETWORK MAC PROTOCOLS**

Figure 7 indicates a taxonomy that classifies UAV ecosystem MAC Protocols. The UAV MAC protocols for UAV Network are discussed in detail.

**6.1. UAV-Based Directional Antenna MAC Protocols**

The following UAV MAC protocol will be addressed on the basis of instructions and design.

**SURVEY ARTICLE**

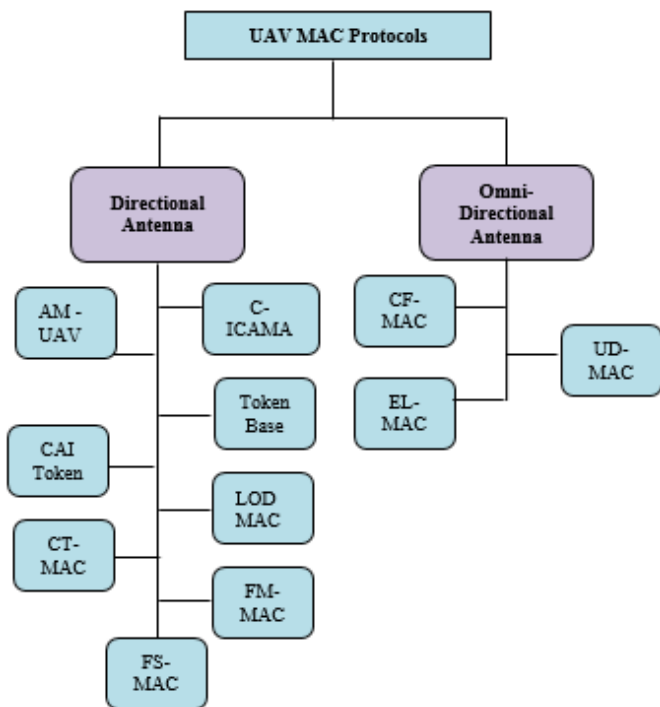

Figure 7 Taxonomy of MAC Protocols

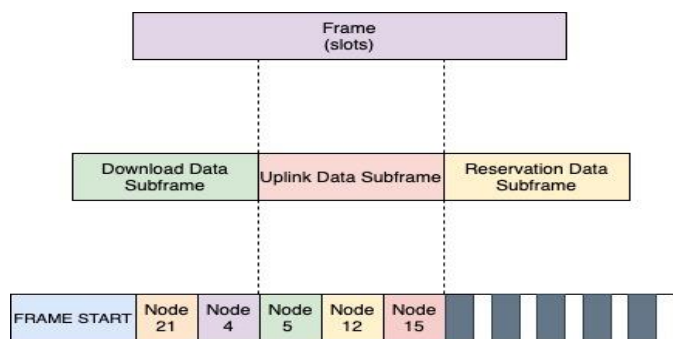

Figure 8 The Frame Structure for C-ICAMA

**6.1.1. C-ICAMA, Centralized Intelligent Channel Assigned Multiple Access**

Gu et al. [15] Suggested MAC protocol for UAVs allocated by a unified intelligent channel (C-ICAMA). The protocol uses phased array antennas for penetrating multiple beams into the soil's cell pattern. The transmission and reception of information to the ground stations on UAVs are from one single channel. Since the protocol is contentious, both nodes try to reach the channel by sending RTS packets. While this protocol is based on a single channel, the latest MAC issues cannot solve. As the frames are store in the links and the performance of the UAVs is degrade causes end-to-end delay problems. The functionality of the protocol is described in different steps that as seen below.

- Step 1: The entire node is directing at the channel access.
- Step 2: The node to reserve will enter into the voting line and wait until the nodes of the polling station.
- Step 3: A single line of communication is available. The time slots are splitting. These slots have a duration that is closer to a data packet's transfer time.
- Step 4: The slots are divided into frames. The frames are consists of down link data and up link data sub frames as seen in figure 8.
- Step 5: Information transferred from surface to UAV or vice versa will process in the uplinks. UAVs will receive reservation packets in the uplink queue, while UAV packets will place down-link.
- Step 6: The sequence has the scale of the channel traffic load. The C-ICAMA protocol guarantees the symmetric network traffic in the middle of up-stream and down-stream are shown in Figure 9.

**6.1.2. Adaptive MAC Protocol for UAV Communication Networks Using Directional Antennas**

Abdel Ilah and Liang [16] Suggested Adaptive MAC UAV Protocol (AMUAV). UAV has two omnidirectional antennas and two primary antennas as well as secondary antennas in this protocol. Primary and secondary antennas are splitting according to their position on the UAV. The primary antenna above the UAV and the secondary antenna below that of the UAV is considering. Moreover, virtually all UAVs have two GPS and IMU estimators, which allow UAVs to be positioned precisely in the region. The AMUAV suggests a new form of heartbeat alert; this message is transmitting until 1 second of operation occurs. The message of heartbeat includes the UAV sender position, orientation, and information of UAV receives a heartbeat alert must answer with the Parameters of the same heart rhythm. The functionality of the AMUAV protocol is described in different steps that as seen below.

- Step 1: The node performs physical transfer and NAV (network allocation vector) sensing before the packet is transmitted. If both the channel and the NAV are sufficient for the UAV is begun to transmitting RTS packets for a certain period. The RTS packet is used for the direction of motion for the omnidirectional antennas, along with UAV number parameters.
- Step 2: Both the first and second UAVs are fitted with a GPS and an IMU to provide high-speed positioning. UAV number two will sense the channel for a short-inter-frame-space (SIFS) period after receiving RTS from UAV number one. If the channel is open, it will respond with

**SURVEY ARTICLE**

the CTS as well as the previous parameters using an omnidirectional antenna.

- Step 3: After the RTS and CTS packets have send and retrieved then all UAVs (nodes) are upgrading their target data tables fully.
- Step 4: Until data transfer begins, the MAC protocol control the distance between all UAVs. If the UAVs are offering each other's omnidirectional cap, data will send through an omnidirectional antenna. If not, AMUAV tracks UAV altitudes. Therefore the UAV transmitter specifies which directional antenna is to use after inspection of the receiver UAV altitude.

- Step 5: After data is gathering, the UAV will adjust its target table on the receiver side and transmit the UAV parameter to ACK through the omnidirectional antenna is shown in figure 10. The antennas are formed based on both the target location and the Euler source angles for error-free transmission. The IEEE 802.11b comparison protocol is much change in terms of efficiency and latency from end to end. Further, it will delay the transition of data packets between an omnidirectional and a directional antenna. Furthermore, it struggles to address the problems with directional antennas, such as concealed and revealed units, surface, and HOL. This protocol is also insufficient to correct the scale even fault tolerance, latency, and scalability.

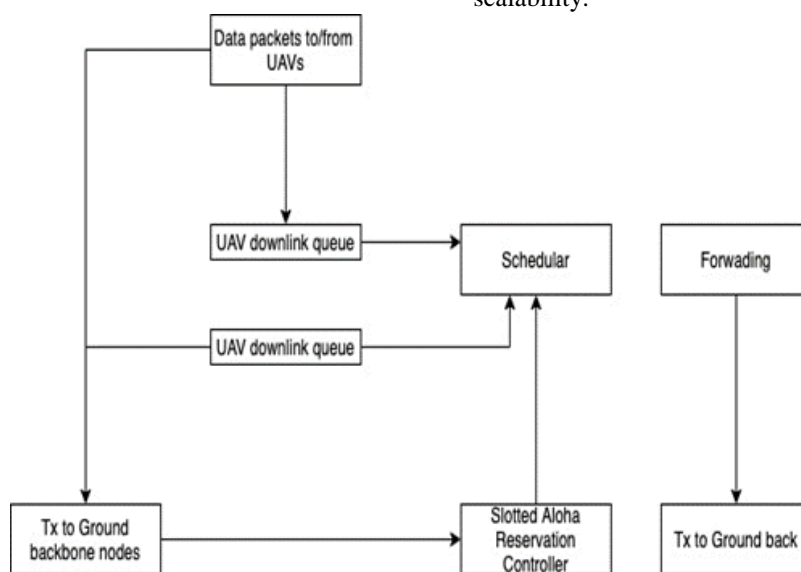

Figure 9 Scheduler for C-ICAMA

6.1.3. Token-Based MAC Protocols

Besides, some researchers suggested token-based MAC protocols for containment-based protocols for UAV networks. Li et al. suggested a token-based MAC device using the UAV network CDMA process. This scheme helps to classify, as the authors claim, the current and existing neighbors of a local UAV. Each UAV has half-duplex antennas for data transmission with the same range of communication. Our antennas are used for data transfer, while other antennas are using for token transmission. The token structure illustrates Figure 11 and, the functionality of the protocol is described in different steps as shown below [37].

- Step 1: Every UAV has to maintain in this scheme two buffer lists (a) Neighbour list (b) Code list. The UAV code list consists of the code for transmitting data that allocate to UAVs. On the other hand, the neighbor list contains UAV identity and address information.
- Step 2: The neighbor list and code list are used in deciding the token node to transfer. The UAV at the top

of NL is chosen as the first UAV token to send the destination.

- Step 3: The source UAV retains a timer for interference-free distribution to decide whether the token transmitted UAV sources are eliminated effectively at the receiver end before the start of further transmission. The time limit is more than twice as long as one side transfer plus the loading time required by a single-hop UAV receiver.
- Step 4: In the event of a crowded channel, UAV transmissions of other UAVs shall be believed to overhear. If the token message collides at the end of the recipient, this device will wait to retransmit the token. The scheme can be embraced as a novel strategy for passing information, helping to locate the missing and new neighbour's. But the token's loss event is not adequately treated. This device fails when a new UAV approaches or exits the UAV cluster. In comparison, half-duplex channel use is an unsuitable collision prevention and spatial reuse approach as seen in Figure 12.



**SURVEY ARTICLE**

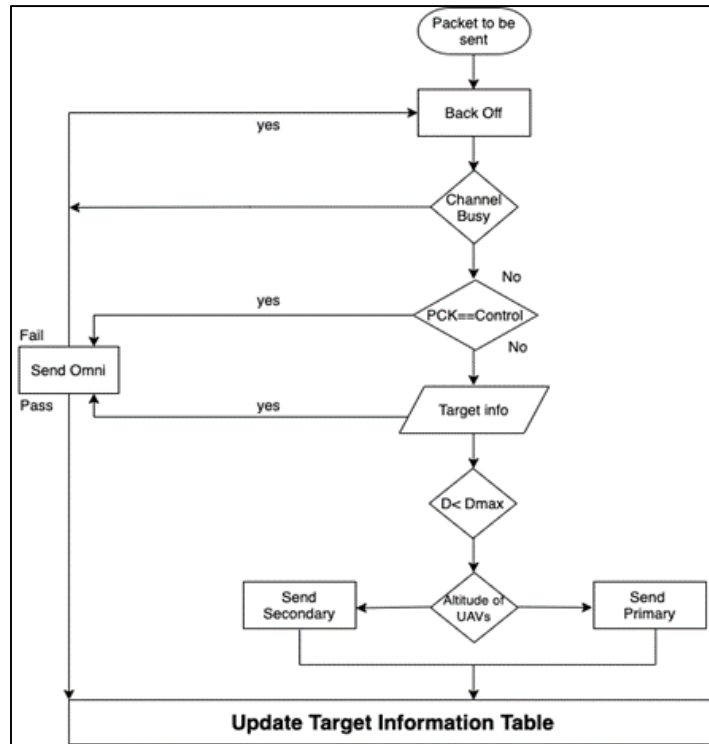

Figure 10 MAC Scheme Flow Chart for AMUAV

Preamble	Source	Destination	RTR	assigned_code	neighbour_list	Code_list	end_of_token
----------	--------	-------------	-----	---------------	----------------	-----------	--------------

Figure 11 Token Structure

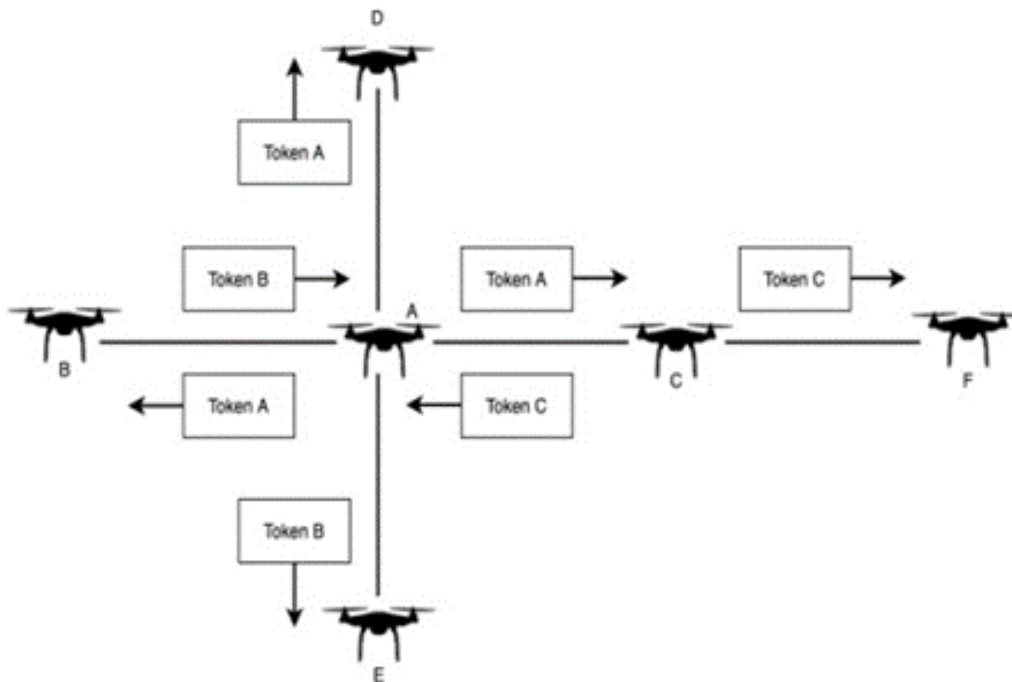

Figure 12 Network Architecture with MAC Scheduling

**SURVEY ARTICLE**

6.1.4. MAC Scheme of Cai Token

Cai et al. suggested another token-based MAC system. The MAC is specially designed for UAV ad hoc systems with multi-packet reception (MPR) and duplex radio capacity. Since UAV networks use half-duplex antennas, the scheme has been developing to address the high degree of packet loss and interferences. This scheme has main objectives (a) minimize the delay, (b) maximize the system throughput. The functionality of the protocol is described in different steps that as seen below [38].

- Step 1: It has two networks, a common network, and a data channel. The common network use to transfer tokens while data channel is being used to transmit the information as seen in Figure 13.
- Step 2: The node that has to share with the knowledge will have a token that extracts the code and automatically passes it to the next closest node. Such as extremely mobile networks even keeping tokens for a long time contributes to latency.

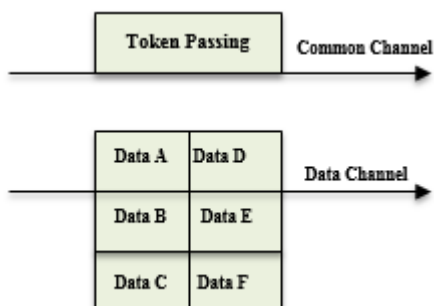

Figure 13 Media Access Control Framework

- Step 3: The token fields winning list for the channel, and the waiting criteria list include the code collection. The code list includes codes for the nodes to retrieve the data frames. Channel gain information can be found in the benefit list of the channel. A list of delays provides an approximate period of expectancy of a transmitter.
- Step 4: The CSI (channel state information) and the lateness criteria are two parameters from which it is possible to obtain each data transfer link node from the token transmission. But a node with a transmitting packet must determine first where the data is to be transmitted based on those parameters.
- Step 5: The CSI and the delay information are believed to be supplied with the token passing by any node concerned. That allows nodes to decide who can move the data to at least a time. Probing further, Results have shown that, in terms of efficiency, the proposed scheme would significantly improve MAC production to reduce latency. Furthermore, because of its size, the use of

duplex antennas remains problematic in the UAV network.

6.1.5. LODMAC: Location Oriented Directional MAC Protocol

Temel and Bekmezci proposed UAV (LODMAC) protocol. The authors conclude that two-directional beam antennas were connecting to each UAV. The first antenna used to relay control packets and position forecasts often referred to as the testing process. The second antenna that transmits the information referred to as a method of transmitting data shown in Figure 14 GPS signal for nearby site recognition is the basis for LODMAC protocol. In this protocol, the UAV must wait to distribute its location information as LODMAC publishes the UAV location using a round-robin algorithm. BTS is finding in LODMAC, the latest control packet. Thus, the receiver will respond to the sender that it carries out the transmission and will not be available for some time. At the coordination level, this protocol detects or regulates the state of data exchange. If the data transmission process of a node is not broadcasting, it is presumed to be idle. The functionality of the protocol is described in different steps that as seen below,[39].

- Step 1: To begin contact, the sender node (UAV) extends its position through the location vector. Location-oriented MAC is used for transmitting an LV packet over one hop propagation across all sectors of a switched beam antenna. After receipt of an LV packet, the nodes will change their DND, existing antenna orientation and connection ID, and their directional neighbor index.

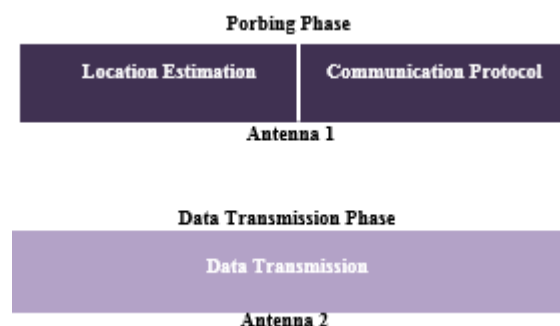

Figure 14 Two-Phase of LODMAC

- Step 2: After efficient position determination, control packets are exchanged through the first antennas.
- Step 3: LODMAC employs the second transceiver for data transfer. Before the data transfer begins, the DND table is queried for the receiver node's positional information. The beam of the antenna is formed to the receiver with this information.
- Step 4: After the DND Table has been checked, a node

**SURVEY ARTICLE**

(UAV) sends RTS to another node and considers the receiver node as idle (UAV). On approval of RTS, the receiver node once the RTS packet has been obtaining, the receiver node awaits SIFS time and responds to DCTS.

- Step 5: Then the data transfer starts by the second transmitter when A Node receives a CTS for a receptor node. In the meantime, a new node (say C) investigates the table and considers node A inactive as the RTS transmission.
- Step 6: Next, BTS packet node A responds to node C. That time the transmission takes is contained in this packet. Node C awaits the continuous transmission of node A. As seen in figure 15, node C sends RTS to node A, and node A replies back with CTS packet. The contact through the second transmitter starts when the control packet is transmitted successfully. This protocol is new, but there are no methods for dealing with multi-transmitters and HOL issues. The latency and low performance of the LV packet are also accomplished in the round-robin mode.

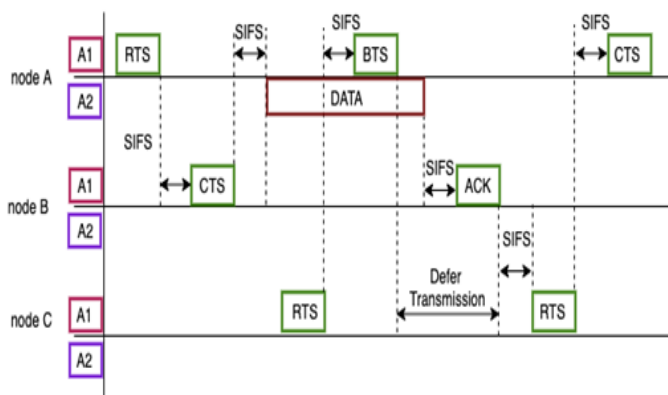

Figure 15 Communication Architecture of LODMAC

6.1.6. CT-MAC Protocol

Wang and Dong are proposing another MAC protocol, For the UAV ad hoc network. The CT-MAC protocol enables MAC to change in recognition missions between CSMA and TDMA in keeping with its function within UAVs. The functionality of the protocol is described in different steps that as seen below.,[40].

- Step 1: The goal is to determine whether or not MAC protocols can be modified jointly, a UAV ad hoc network adaptive mechanism.
- Step 2: To have access, an adaptive MAC layer is applied to the current MAC adaption layer for the set of compatible MAC protocols to run in the various network environment.

- Step 3: For the powerful CT-MAC turn, re-locate on each UAV and GMI position in the GPS, as shown in Figure 16. GMI header modification can help avoid conflicts between different receivers.
- Step 4: Besides, each node will only allow the transmission of data within the slot and save, a special function applied to prevent contexts, as seen in Figure 17 to avoid collision and blockage of each node by TDMA. GPS signal is used for clock signal synchronization so that all nodes have the same time precision. But the interchange between the CSMA and the TDMA in the GPS bases cannot be regarded as fascinating work. Due to the delay in GPS signal, UAV's role in recognition missions contributes to mission failures.



Figure 16 Frame of CT-MAC



Figure 17 Frame Structure of CT-MAC

6.1.7. FM-MAC

FM-MAC is integrating with directional antennas and multi-channel capabilities of FANET's. A mobile forecast concept reservation scheme to solve the problem of interrupting links owing to increased mobility. In contrast, for the priorities-based transfer of the utility package, a pre-emptive approach is often used. The functionality of the protocol is described in different steps that as seen below [41].

MAC Header	Position	Velocity	Packet Payload
------------	----------	----------	----------------

Figure 18 FM-MAC Framework

- Step 1: Acting with a directional antenna poses concerns about how to find another UAV. For this purpose, FM-MAC incorporates into its current MAC frame structure two new sectors i.e, position & speed. The UAVs in a surrounding area are expected to share the velocity of their positions using the frame structure seen in Figure 18.
- Step 2: FM-MAC networks are channels that are divided into one CCH and several SCHs. To provide specific services, CCHI is further divided into Safety Phase (SP) and Channel Reservation Phase (CRP). The CCH function is the protected communication based on the security packages.

**SURVEY ARTICLE**

- Step 3: The protective system uses SCH to prioritize video packet transfers to other packets.

6.1.8. FS-MAC Protocol

The author suggests a synchronous MAC (FS-MAC) fault resistant, which can differentiate between the protocols TDMA and CSMA/CA. The FS-MAC protocol also includes a Functional Practical Byzantine Fault Tolerance (PBFT) and security functions that can be used to make MAC switching decisions based on the results of the evaluation. The functionality of the protocol is described in different steps that are seen below [42].

- Step 1: As seen in Figure 19, the MAC-based Q-learning method will then help to pick the required TDMA and CSMA/CA MAC protocol as the top layer collects input from the network layer.
- Step 2: After encapsulation, the MAC pre-selection operation is employed to select an appropriate MAC protocol for a UAV according to the UAV's current state, which consists of Successful Transferred Amount of Data (STAD) delay, and Packet Retransmission Ratio (PRR).
- Step 3: In special cases, the FS-MAC will also operate where certain functions for pre-selection are not supported. In this case, the UAVs of the recipient and sender migrate jointly into the same protocol for data transmission.

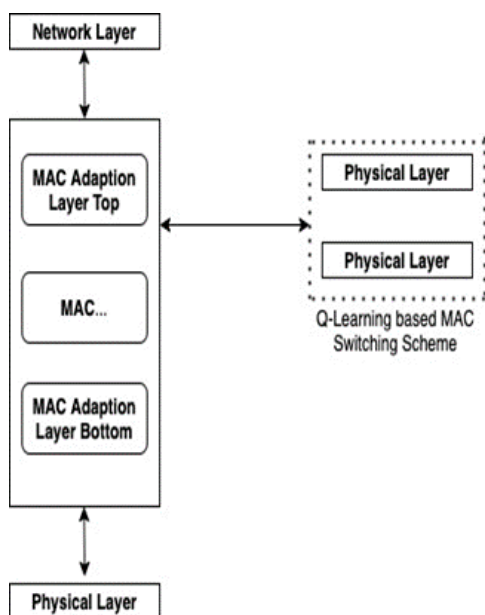

Figure 19 FS-MAC Framework

6.2. Omnidirectional Antennas-Based MAC UAV Protocols

The following are the UAVS MAC protocols focused on omnidirectional antennas.

6.2.1. (CF-MAC): Collision Free MAC (CF-MAC) Protocol

Jiang and Mi introduced a CSMA/TDMA hybrid collision-free MAC protocol for UAV ad hoc networks. The author proposed an MRC-free half-duplex radio protocol. The functionality of the protocol is described in different steps that are seen below [43].

- Step 1: The author uses an area labelling scheme with omnidirectional antennas to remove the issue of directional antennas.
- Step 2: In UAV Ad-Hoc Networks, the CF-MAC is intended to prevent collisions between two hops.
- Step 3: When a node attempts to enter the channel for the first time and finds a time slot, the time is divided into slots as shown in Figure 20. It will sense the channel and determine free time slots based on neighbor frame information (FI), then select one free slot and access it using the CSMA back off process.
- Step 4: CSMA approach is used to solve in case of a collision with an assigned back off time. The area labelling method aims to increase reliability and to prevent collisions but even without MRC, the use of omnidirectional antennas with half-duplex capability results in poor efficiency and connectivity.

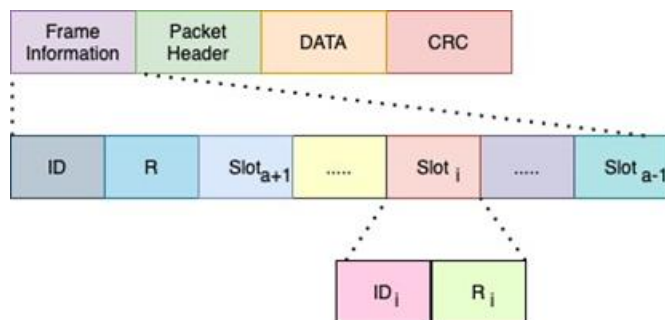

Figure 20 Frame Structure of CF-MAC

6.2.2. UD-MAC

The authors used links Management and Non-Payload Communication to build a delay-tolerant MAC for UAVs (CNPC). The UAVs in UD-MAC must keep notes to provide information on the other UAVs and routes they are pursuing. For exchanging knowledge, the CNPC connection is used. The functionality of the protocol is described in different steps that are seen below [44].

- Step 1: The air-air (A-A) and air-ground (A-G) channels distribute the CNPC packets in two forms of channels. Three kinds of information [12] are found in CNPC packets. 1) GU to UAV command and control results. 2) Information regarding the condition of aircraft from UAVs to GU. 3) Sensing and preventing UAV information



**SURVEY ARTICLE**

- Step 2: The CNPC Information Transfer Uplink channel takes time division multiple access (TDMA). Although the CNPC information exchange downlink channel uses (frequency division multiple access) FDMA.
- Step 3: Through this CNPC link, the UAVs relay the status information and state that they are back on the ground or floating until the energy is available. By using the CNPC connection, they are also split between GPS

codes and velocity to detect their ground units as seen in figure 21.

- Step 4: The nodes have to compete in a time-slot to get the details. On the other hand, the control channels, must assign slots within a UAV two-hop interval.
- Step 5: The coordination role of the UDMAC is shown in Figure 22 by UAVs A, B, C, and GU interacting with each other.

Frame Control	Duration	Transmitter ID	Receiver ID	State	GPS	FCS	Location, Acceleration
---------------	----------	----------------	-------------	-------	-----	-----	------------------------

Figure 21 CNCP Packet Send by UAV

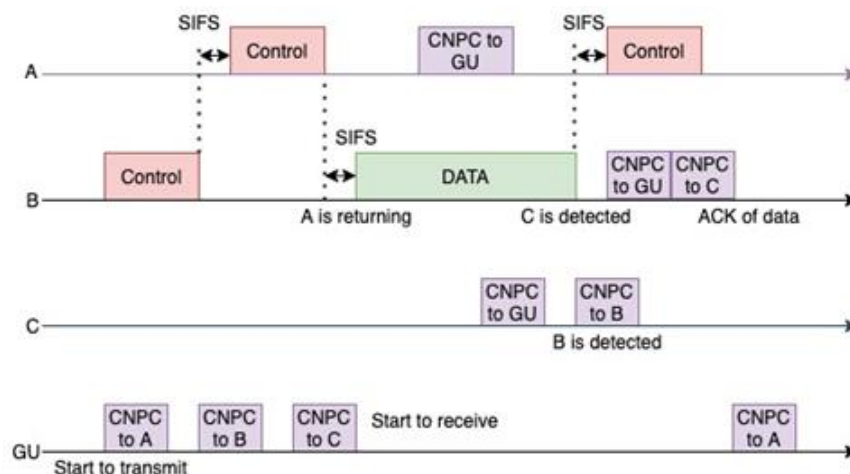

Figure 22 Example of Communication Process

Protocols	A	B	C	D	E	F	G	H	I	J
CF-MAC[43]	x	x	x	x	x	x	x	✓	x	x
FS-MAC[42]	x	x	x	x	✓	x	✓	x	x	x
LODMAC[39]	x	x	x	x	✓	x	✓	x	x	✓
C-ICAMA[15]	x	x	x	x	✓	x	✓	x	x	x
EL-MAC[45]	x	x	x	x	✓	x	✓	x	x	x
AMUAV[16]	x	✓	x	x	✓	x	✓	✓	x	x
FM-MAC[41]	x	x	x	x	✓	x	✓	x	x	x
Y. Cai [38]	x	x	x	x	✓	x	✓	x	x	x
UD-MAC[44]	x	x	x	x	x	x	x	x	x	x
Token Cir[37]	✓	x	✓	x	x	x	✓	x	x	x
CT-MAC[40]	x	x	x	x	✓	x	✓	x	x	x

Table 4: Comparison of the UAV Network MEDIUM Access Control (MAC) Protocols

Note: A-Latency; B- Bit error rate; C-PDR; D- Scalability; E-Throughput; F-Jitter; G-E2E delay; H- Fault tolerance; I- Reliability; J- Fairness index

**SURVEY ARTICLE**

## 6.2.3. EL-MAC

EL- Medium Access Control for UAVs and location recognition that are energy efficient. By optimizing fireflies, the main aim of the EL-MAC is to boost the quality of service (QoS). Moreover, to allow UAV MAC to operate smoothly, an efficient UAV timing slot diagram is expected. The functionality of the protocol is described in different steps that as seen below [45].

- Step 1: The EL-MAC uses the position prediction formulation for the collision avoidance mechanism. This helps to prevent clashes between either their direction or their data transmission in the coordinates of the UAV classes.
- Step 2: EL-MAC works under the concept of a transmission management window for congestion. It applies to the slots allotted to UAVs to fly from one location to another.
- Step 3: It also refers to the transition from UAV to UAV that is energy-conscious.

## 6.3. Comparison of MAC Protocols

Table 4 offers a comparative examination of the Medium Access C protocols mentioned above for UAVs using directional and omnidirectional antennas. The table depicts the Quality of service parameters used in these MAC protocols based on comparisons. To have a summarised view of the various protocols, The MAC protocols and their related functions are categories in this table.

## 7. CONCLUSION

The MAC protocol plays a key role in addressing network size acceptance for UAV networks in use of bandwidth, resolved collisions, allocated capability, higher data rate management, QoS, and range. This workflow is still incremental, and UAV network native MAC protocols also are optically discerned. Many researchers suggested changes to these protocols to make the current protocols workable for UAV scenarios. This paper addressed two MAC protocol groups focused on both directional and omnidirectional antennas. This paper calculates the current industry dynamics and emphasizes the use of cases in UAVs various techniques and requirements. Different functionality requirements and aspects are given in-depth in the design of the MAC protocols. Variants of UAV relationships and related complexity along with a summary of current studies are considered. The paper also presents guidelines on the analysis of MAC protocols as well as addresses many open problems that researchers worldwide should take up to address challenges related to the construction of effective networks with UAVs. To build a solution for multiple attack vectors in UAV networks that are widespread and the protection

vulnerability or problems unique to UAVs will be studied in the future.

## REFERENCES

- [1] Sahil Vashisht, Sushma Jain, Gagangeet Singh Aujla, MAC protocols for unmanned aerial vehicle ecosystems: Review and challenges, *Computer Communications*, Volume 160,2020, Pages 443-463, <https://doi.org/10.1016/j.comcom.2020.06.011>.
- [2] Jyoti and R. S. Bath, "Classification of Unmanned Aerial vehicles: A Mirror Review," 2020 International Conference on Intelligent Engineering and Management (ICIEM), London, United Kingdom, 2020, pp. 408-413.
- [3] A. Vashisth and R. S. Bath, "An Overview, Survey, and Challenges in UAVs Communication Network," 2020 International Conference on Intelligent Engineering and Management (ICIEM), 2020, pp. 342-347, doi: 10.1109/ICIEM48762.2020.9160197
- [4] Bhardwaj, Vinay, Navdeep Kaur, Sahil Vashisht, and Sushma Jain. "SecRIP: Secure and reliable intercluster routing protocol for efficient data transmission in flying ad hoc networks." *Transactions on Emerging Telecommunications Technologies* (2020): e4068.
- [5] A. Vashisth, R. Singh Bath and R. Ward, "Existing Path Planning Techniques in Unmanned Aerial Vehicles (UAVs): A Systematic Review," 2021 International Conference on Computational Intelligence and Knowledge Economy (ICCIKE), 2021, pp. 366-372, doi: 10.1109/ICCIKE51210.2021.9410787.
- [6] Shahi, Gurpreet Singh, Ranbir Singh Bath, and Simon Egerton. "MRGM: an adaptive mechanism for congestion control in smart vehicular network." *International Journal of Communication Networks and Information Security* 12, no. 2 (2020): 273-280.
- [7] Hayat, Samira, Evşen Yanmaz, and Raheeb Muzaffar. "Survey on unmanned aerial vehicle networks for civil applications: A communications viewpoint." *IEEE Communications Surveys & Tutorials* 18, no. 4 (2016): 2624-2661.
- [8] Gupta, Lav, Raj Jain, and Gabor Vaszkun. "Survey of important issues in UAV communication networks." *IEEE Communications Surveys & Tutorials* 18, no. 2 (2015): 1123-1152.
- [9] Gaurav Choudhary, Vishal Sharma, Ilun You, Sustainable and secure trajectories for the military Internet of Drones (IoD) through an efficient Medium Access Control (MAC) protocol, *Computers & Electrical Engineering*, Volume 74, 2019, Pages 59-73, ISSN 0045-7906, <https://doi.org/10.1016/j.compeleceng.2019.01.007>.
- [10] A. Mukherjee, V. Keshary, K. Pandya, N. Dey, S. C. Satapathy, *Flying ad hoc networks: A comprehensive survey*, in *Information and decision sciences*, Springer, 2018, pp. 569–580.
- [11] A. Fotouhi, H. Qiang, M. Ding, M. Hassan, L. G. Giordano, A. Garcia-Rodriguez, J. Yuan, *Survey on UAV cellular communications: Practical aspects, standardization advancements, regulation, and security challenges*, *IEEE Communications Surveys & Tutorials* 21 (2019) 3417– 3442.
- [12] S. Hayat, E. Yanmaz and R. Muzaffar, "Survey on Unmanned Aerial Vehicle Networks for Civil Applications: A Communications Viewpoint," in *IEEE Communications Surveys & Tutorials*, vol. 18, no. 4, pp. 2624-2661, Fourthquarter2016. doi: 10.1109/COMST.2016.2560343.
- [13] Y. Qiao, Y. Zhang and X. Du, "A Vision-Based GPS-Spoofing Detection Method for Small UAVs," 2017 13th International Conference on Computational Intelligence and Security (CIS), Hong Kong, 2017, pp. 312-316, doi: 10.1109/CIS.2017.00074.
- [14] S. Dey, H. Sarmah, S. Samantray, D. Divakar, and S. S. Pathak, "Energy efficiency in wireless mesh networks," in *Proc. IEEE Int. Conf. Comput. Intell. Comput. Res. (ICCI'10)*, Dec. 2010, pp. 1–4.
- [15] Gu, Daniel Lihui, Henry Ly, Xiaoyan Hong, Mario Gerla, Guangyu Pei, and Yeng-Zhong Lee. "C-ICAMA, a centralized intelligent channel assigned multiple access for multi-layer ad-hoc wireless networks with UAVs." In 2000 *IEEE Wireless Communications and Networking Conference*. Conference Record (Cat. No. 00TH8540), vol. 2, pp. 879-

## SURVEY ARTICLE

884. IEEE, 2000.
- [16] A. I. Alshbatat, L. Dong, Adaptive mac protocol for UAV communication networks using directional antennas, in *Networking, Sensing and Control (ICNSC)*, 2010 International Conference on, IEEE, 2010, pp. 598–603.
- [17] Bekmezci, I., O. K. Sahingoz and S. Temel. "Flying Ad-Hoc Networks (FANETs): A survey." *Ad Hoc Networks* 11 (2013): 1254-1270.
- [18] Romit Roy Choudhury, Xue Yang, Ram Ramanathan, and Nitin H. Vaidya. 2002. Using directional antennas for medium access control in ad hoc networks. In *Proceedings of the 8th annual international conference on Mobile computing and networking MobiCom '02* Association for Computing Machinery, New York, NY, USA, 59–70. DOI:https://doi.org/10.1145/570645.570653
- [19] A. Jindal, G. S. Aujla, N. Kumar, R. Chaudhary, M. S. Obaidat and I. You, "SeDaTiVe: SDN-Enabled Deep Learning Architecture for Network Traffic Control in Vehicular Cyber-Physical Systems," in *IEEE Network*, vol. 32, no. 6, pp. 66-73, November/December 2018, doi: 10.1109/MNET.2018.1800101.
- [20] M. Singh, G. S. Aujla and R. S. Bali, "ODOB: One Drone One Block-based Lightweight Blockchain Architecture for Internet of Drones," *IEEE INFOCOM 2020 - IEEE Conference on Computer Communications Workshops (INFOCOM WKSHPS)*, Toronto, ON, Canada, 2020, pp. 249-254, doi: 10.1109/INFOCOMWKSHPS50562.2020.9162950.
- [21] Sahil Vashisht, Sushma Jain, An energy-efficient and location-aware Medium Access Control for quality of service enhancement in unmanned aerial vehicular networks, *Computers & Electrical Engineering*, Volume 75, 2019, Pages 202-217, ISSN 00457906, https://doi.org/10.1016/j.compeleceng.2019.02.021
- [22] Cao, D., Zheng, B., Ji, B., Lei, Z., & Feng, C. (2020). A robust distance-based relay selection for message dissemination in vehicular network. *Wireless Networks*, 26, 1755-1771.
- [23] S. Garg, G. S. Aujla, N. Kumar and S. Batra, "Tree-Based Attack-Defense Model for Risk Assessment in Multi-UAV Networks," in *IEEE Consumer Electronics Magazine*, vol. 8, no. 6, pp. 35-41, 1 Nov. 2019, doi: 10.1109/MCE.2019.2941345.
- [24] Wang, Jin; Gao, Yu; Liu, Wei; Sangaiah, Arun K.; Kim, Hye-Jin. 2019. "Energy Efficient Routing Algorithm with Mobile Sink Support for Wireless Sensor Networks" *Sensors* 19, no. 7: 1494. https://doi.org/10.3390/s19071494
- [25] B. Yang, T. Taleb, Y. Fan and S. Shen, "Mode Selection and Cooperative Jamming for Covert Communication in D2D Underlaid UAV Networks," in *IEEE Network*, vol. 35, no. 2, pp. 104-111, March/April 2021, doi: 10.1109/MNET.011.2000100.
- [26] C. -H. Liu, D. -C. Liang, M. A. Syed and R. -H. Gau, "A 3D Tractable Model for UAV-Enabled Cellular Networks With Multiple Antennas," in *IEEE Transactions on Wireless Communications*, doi: 10.1109/TWC.2021.3051415.
- [27] D. -H. Tran, T. X. Vu, S. Chatzinotas, S. ShahbazPanahi and B. Ottersten, "Coarse Trajectory Design for Energy Minimization in UAV-Enabled," in *IEEE Transactions on Vehicular Technology*, vol. 69, no. 9, pp. 9483-9496, Sept. 2020, doi: 10.1109/TVT.2020.3001403.
- [28] Altawy, Riham & Youssef, Amr. (2016). Security, Privacy, and Safety Aspects of Civilian Drones: A Survey. *ACM Transactions on Cyber-Physical Systems*. 1. 1-25. 10.1145/3001836.
- [29] Y. Zeng, R. Zhang, and T. J. Lim, "Wireless communications with unmanned aerial vehicles: opportunities and challenges," in *IEEE Communications Magazine*, vol. 54, no. 5, pp. 36-42, May 2016, doi: 10.1109/MCOM.2016.7470933.
- [30] S. Vashist and S. Jain, "Location-Aware Network of Drones for Consumer Applications: Supporting Efficient Management Between Multiple Drones," in *IEEE Consumer Electronics Magazine*, vol. 8, no. 3, pp. 68-73, May 2019, doi: 10.1109/MCE.2019.2892279.
- [31] I. W. Group, et al., Part11: Wireless LAN medium access control (mac) and physical layer (PHY) specifications, ANSI/IEEE Std. 802.11 (1999).
- [32] Vaduvur Bharghavan, Alan Demers, Scott Shenker, and Lixia Zhang. 1994. MACAW: a media access protocol for wireless LAN's. *SIGCOMM Comput. Commun. Rev.* 24, 4 (Oct. 1994), 212–225. DOI:https://doi.org/10.1145/190809.190334
- [33] J. Mietzner, R. Schober, L. Lampe, W. H. Gerstacker, and P. A. Hoeher. 2009. Multiple-antenna techniques for wireless communications - a comprehensive literature survey. *Commun. Surveys Tuts.* 11, 2 (April 2009), 87–105. DOI:https://doi.org/10.1109/SURV.2009.090207
- [34] R. R. Choudhury, X. Yang, R. Ramanathan, N. H. Vaidya, On designing mac protocols for wireless networks using directional antennas, *IEEE transactions on mobile computing* 5 (2006) 477–491
- [35] L. Catarinucci, S. Guglielmi, L. Mainetti, V. Mighali, L. Patrono, M. L. Stefanizzi, L. Tarricone, An energy-efficient mac scheduler based on a switched-beam antenna for wireless sensor networks (2013).
- [36] D. L. Gu, G. Pei, H. Ly, M. Gerla, B. Zhang, and X. Hong, "UAV aided intelligent routing for an ad-hoc wireless network in single-area theater," 2000 *IEEE Wireless Communications and Networking Conference. Conference Record (Cat. No.00TH8540)*, Chicago, IL, 2000, pp. 1220-1225 vol.3, doi: 10.1109/WCNC.2000.904805.
- [37] A. I. Alshbatat, L. Dong, Adaptive mac protocol for UAV communication networks using directional antennas, in *Networking, Sensing and Control (ICNSC)*, 2010 International Conference on, IEEE, 2010, pp. 598–603.
- [38] J. Li, Y. Zhou, L. Lamont, M. D'eziel, A token circulation scheme for code assignment and cooperative transmission scheduling in CDMA-based UAV ad hoc networks, *Wireless networks* 19 (2013) 1469–1484
- [39] Y. Cai, F. R. Yu, J. Li, Y. Zhou, L. Lamont, Medium access control for the unmanned aerial vehicle (UAV) ad-hoc networks with full-duplex radios and multipacket reception capability, *IEEE Transactions on Vehicular Technology* 62 (2013) 390-394
- [40] Samil Temel, Ilker Bekmezci, LODMAC: Location Oriented Directional MAC protocol for FANETs, *Computer Networks*, Volume 83, 2015, Pages 76-84, ISSN 1389-1286, https://doi.org/10.1016/j.comnet.2015.03.001.
- [41] W. Wang, C. Dong, H. Wang, and A. Jiang, "Design and Implementation of Adaptive MAC Framework for UAV Ad Hoc Networks," in 2016 12th International Conference on Mobile Ad-Hoc and Sensor Networks (MSN), Hefei, 2016 pp. 195-201. doi: 10.1109/MSN.2016.039
- [42] G. Wu, C. Dong, A. Li, L. Zhang, and Q. Wu, "FM-MAC: A Multi-Channel MAC Protocol for FANETs with Directional Antenna," 2018 *IEEE Global Communications Conference (GLOBECOM)*, Abu Dhabi, United Arab Emirates, 2018, pp. 1-7, doi: 10.1109/GLOCOM.2018.8648025.
- [43] Zhang, Min, C. Dong, and Y. Huang. "FS-MAC: An Adaptive MAC Protocol With Fault-Tolerant Synchronous Switching for FANETs." *IEEE Access* 7 (2019): 80602-80613.
- [44] A. Jiang, Z. Mi, C. Dong, and H. Wang, "CF-MAC: A collision-free MAC protocol for UAVs Ad-Hoc networks," 2016 *IEEE Wireless Communications and Networking Conference*, Doha, 2016, pp. 1-6, doi: 10.1109/WCNC.2016.7564844.
- [45] J. Sun and Z. Gu, "EL-MAC Protocol for Wireless Sensor Network," 2008 4th International Conference on Wireless Communications, Networking and Mobile Computing, 2008, pp. 1-4, doi: 10.1109/WiCom.2008.947.
- [46] Shahi, G.S., Bath, R.S. and Egerton, S., 2020. A comparative study on efficient path finding algorithms for route planning in smart vehicular networks. *International Journal of Computer Networks and Applications*, 7(5), pp.157-166.
- [47] G. S. Shahi, R. Singh Bath and S. Egerton, "PTFM: Pre-processing Based Traffic flow Mechanism for Smart Vehicular Networks," 2021 2nd International Conference on Intelligent Engineering and Management (ICIEM), 2021, pp. 119-126, doi: 10.1109/ICIEM51511.2021.9445291.

**SURVEY ARTICLE**

## Authors



**Jyoti** is a regular PhD. Research Scholar in the School of Computer Applications at Lovely Professional University, Punjab, India. She has completed her Masters of Computer Applications in 2017 from Lovely Professional University, Punjab, India. Her research interests include pervasive computing, wireless communication, AI and Machine Learning.



**Ranbir Singh Batth** is working as an Associate Professor in the School of Computer Science and Engineering and he also serves as an International coordinator at Lovely Professional University, Punjab, India. He has received his Ph.D. from IKG Punjab Technical University, Kapurthala, Punjab, India in 2018 and the Master degree in Computer Engineering from Punjabi University, Patiala. His research interests include Wireless communication, Cloud Computing, Network Security, Vehicular Ad Hoc Networks, Internet of Things, Machine Learning, Deep Learning, pervasive computing, Intelligent Transportation Systems, and Mobile computing. He also serves as an editorial member, guest editor, and reviewer for various reputed International journals. He has been the organizing chair, session chair and advisory member for various reputed International conferences. He is an active member of ACM and IEEE computer Society.



**Sahil Vashisht** (MIEEE) is currently working as an Associate Professor with the Computer Science and Engineering Department, Shree Guru Gobind Singh Tricentenary University; Gurugram. He has received his M.E. degree from the Punjab Technical University, Punjab, India, in 2013, and the Ph.D. degree from the Thapar Institute of Engineering and Technology, Punjab, India, in 2020. His research interests include unmanned ad-hoc networks, software defined networking (SDN), Internet of Things (IoT), public key cryptography, cloud computing, information dissemination, and Intelligent Transportation Systems.

**How to cite this article:**

Jyoti, Ranbir Singh Batth, Sahil Vashisht “A Survey of Medium Access Control Protocols for Unmanned Aerial Vehicle (UAV) Networks”, International Journal of Computer Networks and Applications (IJCNA), 8(3), PP: 238-257, 2021, DOI: 10.22247/ijcna/2021/209191.