



# Design and Implementation of a Smart Home for the Elderly and Disabled

Resul Das

Department of Software Engineering, Firat University, 23119, Elazig, Turkey  
rdas@firat.edu.tr

Gurkan Tuna

Department of Computer Programming, Trakya University, 22020, Edirne, Turkey  
gurkantuna@trakya.edu.tr

Ayse Tuna

School of Foreign Languages, Trakya University, 22030, Edirne, Turkey  
aysetuna@trakya.edu.tr

**Abstract** –Different from the past, in recent years, an increasing number of technology solutions have been started to be designed for the elderly and disabled due to the aging population and increasing awareness about common problems of the disabled. In smart homes, a group of smart, networked devices and sensors can help make the elderly and disabled more independent by letting family members, relatives and doctors keep tabs from afar. Because there is significant interest from care providers who prefer to keep the elderly and disabled in their houses rather than caring them in assisted-living centers. Accordingly, in this study, a sample application of smart home technology is presented. In the presented application, a group of sensors are used to build an autonomous smart home. Although the presented application is just a simple example of how smart homes can be used, it has the potential of affecting all areas improving day to day life of the elderly and disabled.

**Index Terms** – Smart homes, networked sensors, intelligent monitoring, accessibility, prototype smart home.

## 1. INTRODUCTION

According to the recent statistics, there is increasing number of elderly and disabled people. Physically, elderly people are not strong enough and hence are prone to different types of accidents. On the other hand, disabled people are handicapped and cannot perform some movements and activities. For many of the elderly and disabled, one of the best choices may be an assisted-living facility. However, it costs a great deal amount per year.

Although most of the elderly and disabled prefer to live in their homes, their activities and health must be constantly monitored so that immediate help can be provided. Smart homes can be described as technologically advanced homes which enable domestic task automation, easier communication, and higher security. Smart homes can greatly contribute to the

enhancement of the lives of the elderly and disabled by allowing them to stay in their homes where they feel more comfortable. Since smart homes have been geared to provide special needs of the elderly and disabled, they can help care providers to improve the quality of provided services in terms of many aspects. Smart home systems can generally be installed and maintained in residential environments without any complexity. They can be realized using different visible and/or almost invisible components with different functions. Mostly, invisible components increase the acceptance level to use the smart home automation system in a household environment [1-3].

In a smart home, along with a complementary electronic system, intelligent monitoring software monitors the usage of household electronic appliances, collects data from various sensors and detectors, recognizes the activity pattern in real-time and then interprets all the essential activities including preparing breakfast, lunch and dinner, rest room use, showering, and sleeping.

For the elderly and disabled, a smart home gives them opportunity for independence and safety and this way helps them gain confidence and determination by providing many types of emergency assistance systems, security features, automated timers, fall prevention features, warnings and alerts [1]. In addition, a smart home makes it possible for family members and relatives to monitor their loved ones remotely with an internet connection.

In this paper, we review smart home technology and present its benefits. In addition, we present the details of a prototype smart home application. The rest of the paper is organized as follows. Smart homes and their components are reviewed in Section 2.

## RESEARCH ARTICLE

Literature review is presented in Section 3. Section 4 explains the design of a sample smart home solution. Finally, the paper is concluded in Section 5.

### 2. SMART HOMES FOR THE ELDERLY AND DISABLED

Smart homes with state-of-the-art sensor technology constitute in-home and self-learning care solutions can take some of that worry off by helping to constantly monitoring the elderly and disabled. A smart home typically consists of a control panel, a set of distributed sensors and motion detectors to monitor a person's movement around the home, track the status of water faucets and stovetops and recognize the use of electrical appliances, a set of audio – visual based systems, mobile and web based applications, a remote management tool, and a self-learning monitoring system backed by a set of machine learning algorithms and analytics [1-5]. Smart home systems aim to collect real-time information on monitored people' daily activity levels and this way learn recognition of their personal patterns. Whenever those monitored patterns deviate from the norm patterns, smart home systems alert both caregivers and family members letting them take immediate action [6-10]. As a complementary feature, in addition to proving entrance security, smart home systems monitor fire and water leakage, too.

Smart home functions generally rely on a wireless sensor network. The wireless sensor network consists of a number of distributed sensor nodes deployed in the environment to measure physiological parameters [11-14]. At hardware level, the wireless sensor network is typically in form of star topology and a central coordinator of the sensor nodes collects the data from the sensors connected to various appliances. As the wireless sensor network collects data about the monitored person's activities, it recognizes activities of daily living and life styles of elderly and disabled people living alone. Using the generated activity pattern, smart homes make it possible to predict the unusual behavior of the monitored person based on the classification model of regular and irregular sensor activity [15]. Smart homes rely on a machine learning based software application to recognize normal routines and send a message to family members, relatives or medical personnel if something changes suddenly. Wireless sensor network-based smart home systems can be installed in existing home environments with little or no modifications or damage. The great progress in the industry standards and installation of lightweight wireless networking hardware has proved that ZigBee, a low-cost, low-power, and less-complex wireless standard, is well suited for smart home systems [16]. The common requirements of smart home systems can be listed as follows [2]:

- Smart home systems must be open to improvements and be scalable.

- The sensors should be reduced in size and easily installed in household appliances so that they can be almost completely invisible.
- The sensors must be highly accurate.
- Smart home systems must be easily-deployable in different home environments.
- Comprehensive analyses need to be conducted to predict the abnormal situation of the monitored person.

### 3. RELATED WORK

Since most smart home implementations generally make use of a wireless sensor network, researchers focus not only on hardware and software technologies designed to implement smart home functions but also communication technologies [14, 15]. From a broader point of view, based on the functional areas of provided services, smart homes can be divided into four main classes [17-21], namely a) Health Care based, b) Entertainment based, c) Security based Smart Homes, and d) Energy Efficiency and Management based. Considering the recent developments on wireless networking technologies for short-range applications and the communication requirements in the context of the smart home functional areas must be analyzed properly in order to qualify the suitability of candidate wireless standards [17].

Liu in [22] presents the design and implementation of a prototype smart home system based on ZigBee and GSM/GPRS network. The author explains not only the design of the home network but also how the smart home functions are remotely monitored and controlled. Mendes et al. in [17] investigate the suitability of short-range wireless technologies for smart home services. The authors prove that none of the analyzed wireless protocols alone appears to satisfy the communication requirements of smart home functional areas as a whole. However, ZigBee stands out as the best one for smart home network services with low to medium data rates and reliable data communication.

In order to mitigate the impact of wireless interference on smart home networks, eliminate the need for relay nodes and reduce unnecessary energy consumption, Li and Lin in [23] combines the advantages of wireless sensor networks and power line communications. The architecture they proposed employs the power line communication as the network backbone and the wireless sensor network for data sensing and is scalable. Similarly, Ferreira et al. in [24] investigate the use of ultra wide band receivers for low bit-rate data communication transceivers for smart home applications. On the other hand, Tiwari et al. in [25] propose the use of visible light time division duplex technique for bidirectional data transmission between multiple devices.

Although design and development of smart home systems for the elderly has gathered a lot of interest in both the academia

**RESEARCH ARTICLE**

and the industry [26], most of them focus of sensor technologies and communication requirements. However, the major problem here is that most of the available sensors are unable to make the distinction in the monitored environment [27]. In this respect, Charlton et al. in [28] propose a system to monitor daily activities of the elderly in their living environment. The proposed system includes a set of motion sensors network deployed on different areas and an electronic patch worn by the monitored person to identify him/her and detect falls. The proposed system relies on a novel analysis algorithm to detect abnormal situations and alert the nursing staff in real time.

Although preprogrammed automatic homes help the disabled and elderly overcome their handicap, integrating self-adapting intelligence to the homes can provide more benefits in the long term. Artificial neural networks can play an important role in the design and development of smart home systems [29], especially for the detection and recognition of activities of daily life. For this goal, [30] proposes two types of artificial neural networks and proves their effectiveness. Similarly, [31] proves the stability of an artificial neural network based solution for developing personalized smart home systems.

**4. PROPOSED SMART HOME APPLICATION**

As shown in Figure 1, similar to common smart home systems, a set of sensors and detectors are used to gather data and control actions/events. The data gathered by the sensors are sent to the monitoring software running on the Arduino board [32, 33] shown at the center in Figure 1. The values in the gathered data are sent to the system's users and are compared with the previously set values to decide whether to trigger an alert/alarm or not. As shown in Figure 2, a prototype smart home was developed in this study to carry out a set of experiments. Before the installation, the system was designed and tested using Fritzing as shown in Figure 3 [34].

In the prototype home, when someone opens the door, the lighting system is automatically switched on. When the user passes to another room from the entrance, the lighting system is automatically switched off. Since the inputs and outputs of the proposed smart home systems cannot be handled by standard Arduino boards which have limited number of inputs and outputs, an Arduino Mega board was used. An Arduino Ethernet shield shown in Figure 4 was used to provide communication between the sensors and the Arduino Mega board. An Arduino Ethernet shield was used to process and send the gathered data to the system's users, and make the system be remotely manageable.

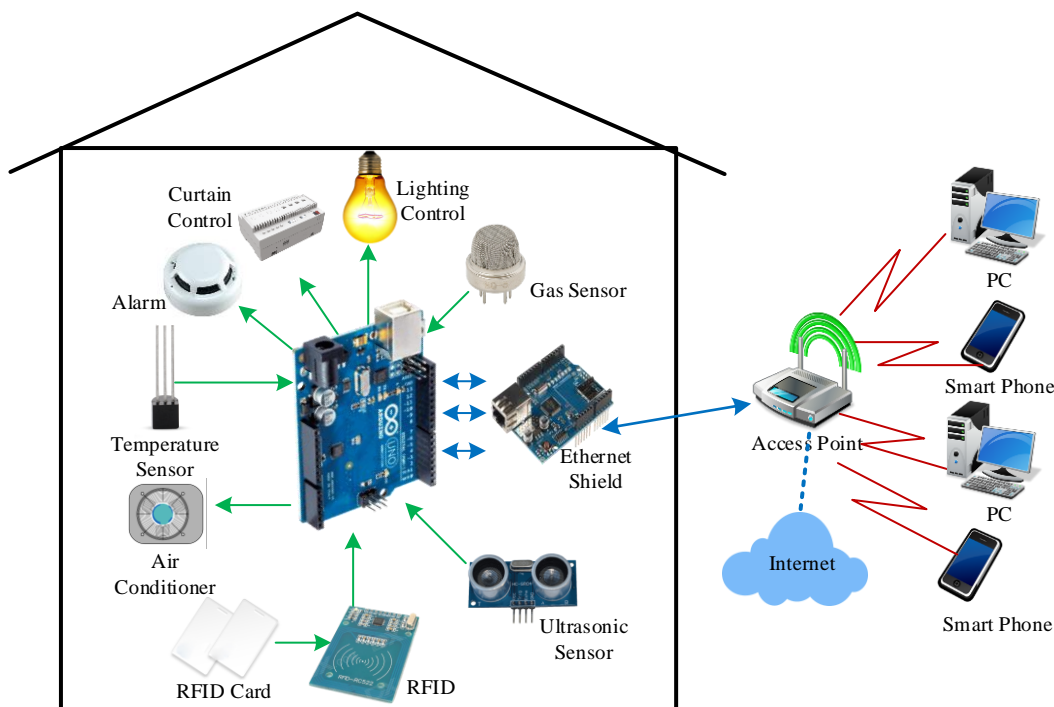

Figure 1: Proposed smart home application.

**RESEARCH ARTICLE**



Figure 2: Prototype smart home application.

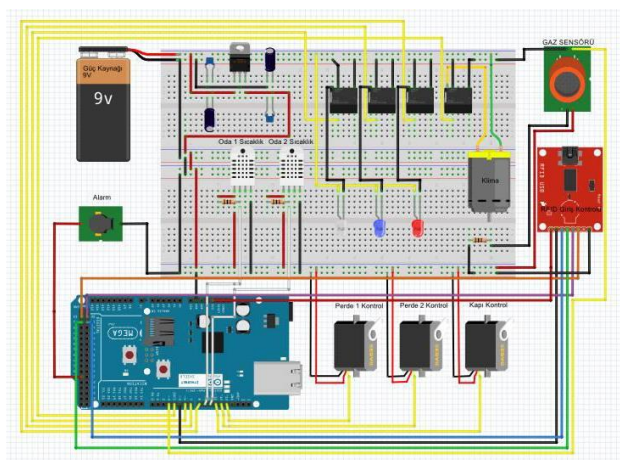

Figure 3: Designing the proposed smart home system using Fritzing [34].

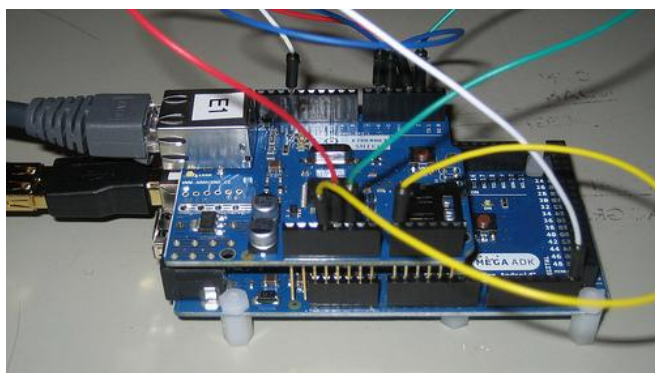

Figure 4: Providing communication ability to various sensors.

The monitoring software has a web-based interface and hence is accessible by mobile devices such as smart phones. In the web-based interface, the user is able to manage some specific activities, see triggered alarms/alerts, and read current or logged sensor values. Whenever a user accesses the monitoring software, the user's identity, login and logout dates and times,

and the user's activities on the monitoring software are recorded. The application presented in this paper is just a simple example of smart home applications and it is still under development.

**5. CONCLUSION**

Needless to say that efficient care enables the elderly and disabled to enjoy the comfort of living at home with full confidence and peace of mind for both themselves and their family members and relatives. This can be offered by using a combination of existing or emerging technological solutions and enables seamlessly learning the living patterns of the elderly and disabled to provide personalized care in a proactive way by monitoring and analyzing daily activities, and alerting the healthcare providers and relatives when early warning signals appear in order to prevent emergency situations.

In this study, a sample application of smart home technology consisting of a number of networked sensors is presented. Although it is just a very simple example of smart homes, it shows that smart homes have the potential of affecting all areas of day to day life of the elderly and disabled. In our future work, we are going to improve the prototype system with a software application and a set of sensors to continuously monitor the in-home activity and generate the sensor activity pattern to analyze and foresee the changes in daily activities of the monitored person.

**REFERENCES**

- [1] Lê, Q., Nguyen H. B. and Barnett, T. (2012). "Smart Homes for Older People: Positive Aging in a Digital World", *Future Internet*, 4(2), 607-617.
- [2] Gaddam, A., Mukhopadhyay, S. C. and Gupta, G. S. (2010). "Towards the Development of a Cognitive Sensors Network Based Home for Elder Care", 6th International Conference on Wireless and Mobile Communications, 484-491.
- [3] Das, R., Tuna, G., (2015). "Machine-to-Machine Communications for Smart Homes", *International Journal of Computer Networks and Applications (IJCNA)*, EverScience Publications, 2 (4), 196-202.
- [4] Moutacalli, M. T., Marmen, V., Bouzouane, A. and Bouchard, B., (2013). "Activity Pattern Mining using Temporal Relationships in a Smart Home", *IEEE Symposium on Computational Intelligence in Healthcare and e-health (CICARE)*, 83-87.
- [5] Manley, E. D. and Deogun, J. S. (2007). "Location Learning for Smart Homes", 21st International Conference on Advanced Information Networking and Applications Workshops (AINAW'07).
- [6] Wang, J., Zhang, Z., Li, B., Lee, S. and Sherratt, R. S., (2014). "An Enhanced Fall Detection System for Elderly Person Monitoring", *IEEE Transactions on Consumer Electronics*, 60(1), 23-29. DOI: 10.1109/TCE.2014.6780921
- [7] Jalal, A., Uddin, M. Z. and Kim, T.-S., (2012). "Depth Video-based Human Activity Recognition System Using Translation and Scaling Invariant Features for Life Logging at Smart Home", *IEEE Transactions on Consumer Electronics*, 58(3), 863-871. DOI: 10.1109/TCE.2012.6311329
- [8] Jovanov, E., Lords, A., Raskovic, D., Cox, P., Adhami, R. and Andrasik, F. (2003). "Stress monitoring using a distributed wireless intelligent sensor system", *IEEE Engineering in Medicine and Biology Magazine*, 22(3), 49-55.

**RESEARCH ARTICLE**

- [9] Jalal, A. and Kamal, S., (2014). "Real-Time Life Logging via a Depth Silhouette-based Human Activity Recognition System for Smart Home Services", In Proceedings of 11th IEEE International Conference on Advanced Video and Signal Based Surveillance (AVSS), 74-80.
- [10] Son, Y. -S., Jo, J., Park, J. -H. and Pulkkinen, T., (2013). "Diabetic Patient Care using Home User Activity Recognition", ICTC 2013, 191-196.
- [11] Alemdar, H. and Ersoy, C., (2010). "Wireless sensor networks for healthcare: A survey, Computer Networks", 54(10), 2688-2710. DOI: 10.1016/j.comnet.2010.05.003
- [12] Istepanian, R. S. H., Jovanov, E. and Zhang, Y. T., (2004). Guest Editorial Introduction to the Special Section on M-Health: Beyond Seamless Mobility and Global Wireless Health-Care Connectivity. IEEE Transactions on Information Technology in Biomedicine, 8(4), 405-414. DOI: 10.1109/TITB.2004.840019
- [13] Akyildiz, I. F., Su, W., Sankarasubramanian, Y. and Cayirci, E., (2002). "Wireless sensor networks: a survey", Computer Networks, Elsevier, 38, 393-422. DOI: 10.1016/S1389-1286(01) 00302-4.
- [14] Suryadevara, N. K. and Mukhopadhyay, S. C., (2011). "Wireless sensors network based safe home to care elderly people: A realistic approach", 2011 IEEE Recent Advances in Intelligent Computational Systems (RAICS), 1-5.
- [15] Tuna, A., Das, R., and Tuna, G., (2015). "Integrated Smart Home Services and Smart Wearable Technology for the Disabled and Elderly," In Proceedings of 4th International Conference on Data Management Technologies and Applications, ISBN 978-989-758-103-8, pp. 173-177, DOI: 10.5220/0005552001730177.
- [16] *Internet*: The ZigBee Alliance, <http://www.zigbee.org> [Accessed 8 June 2015].
- [17] Mendes, T. D. P., Godina, R., Rodrigues, E. M. G., Matias, J. C. O., Catalao, J. P. S., (2015). "Smart and energy-efficient home implementation: Wireless communication technologies role," 2015 IEEE 5th International Conference on Power Engineering, Energy and Electrical Drives (POWERENG), Riga, May 11-13, pp. 377-382.
- [18] F. Viani, F. Robol, A. Polo, P. Rocca, G. Oliveri and A. Massa, (2013). "Wireless Architectures for Heterogeneous Sensing in Smart Home Applications: Concepts and Real Implementation," In Proceedings of the IEEE, vol. 101, no. 11, pp. 2381-2396.
- [19] T. Li, N. B. Mandayam and A. Reznik, (2013). "A Framework for Distributed Resource Allocation and Admission Control in a Cognitive Digital Home," IEEE Transactions on Wireless Communications, vol. 12, no. 3, pp. 984-995, DOI: 10.1109/TWC.2012.011513.111495.
- [20] T. Li, J. Ren and X. Tang, "Secure wireless monitoring and control systems for smart grid and smart home," IEEE Wireless Communications, vol. 19, no. 3, pp. 66-73, 2012. DOI: 10.1109/MWC.2012.6231161.
- [21] P. Dawadi, D. Cook and M. Schmitter-Edgecombe, "Automated Cognitive Health Assessment Using Smart Home Monitoring of Complex Tasks," IEEE Transactions on Systems, Man, and Cybernetics: Systems, vol. 43, no. 3, pp. 1302-1313, 2013. DOI: 10.1109/TSMC.2013.2252338
- [22] Zhen-Ya Liu, "Hardware Design of Smart Home System based on ZigBee Wireless Sensor Network," AASRI Procedia, vol. 8, pp. 75-81, 2014.
- [23] Mingfu Li and Hung-Ju Lin, (2015), "Design and Implementation of Smart Home Control Systems Based on Wireless Sensor Networks and Power Line Communications," IEEE Transactions on Industrial Electronics, 62(7), pp. 4430-4442, DOI: 10.1109/TIE.2014.2379586
- [24] Ana Luiza S. Ferreira, Zhi Quan and Moisés V. Ribeiro, (2012). "Robust and Reduced-Rank UWB Receiver for Green and Smart Home Communication based on Power Line," 2012-16th IEEE International Symposium on Power Line Communications and Its Applications (ISPLC), Beijing, March 27-30, pp. 218-223.
- [25] Samrat Vikramaditya Tiwari, Atul Sewaiwar, and Yeon-Ho Chung, (2015), "Smart Home Technologies using Visible Light Communication," 2015 IEEE International Conference on Consumer Electronics (ICCE), Las Vegas, NV, January 9-12, pp. 379-380.
- [26] T. Gentry, (2009). "Smart homes for people with neurological disability: state of the art," NeuroRehabilitation, vol. 25, no. 3, pp. 209-217, DOI: 10.3233/NRE-2009-0517.
- [27] M. Chan, E. Campo, D. Estève, and J. Y. Fourniols, (2009). "Smart homes – current features and future perspectives," Maturitas, vol. 64, no. 2, pp. 90-97, DOI: 10.1016/j.maturitas.2009.07.014.
- [28] Y. Charlon, W. Bourennane, F. Bettahar, and E. Campo, (2013). "Activity monitoring system for elderly in a context of smart home," IRBM, 34(1), pp. 60-63, DOI: 10.1016/j.irbm.2012.12.014.
- [29] Zheng, H., Wang, H., Black, N., (2008). "Human Activity Detection in Smart Home Environment with Self-Adaptive Neural Networks," IEEE International Conference on Networking, Sensing and Control, Sanya, April 6-8, 2008, pp. 1505-1510.
- [30] Hussein, A., Adda, M., Atieh, M., Fahs, W., (2014). "Smart Home Design for Disabled People based on Neural Networks," Procedia Computer Science, 37, pp. 117-126, DOI: 10.1016/j.procs.2014.08.020
- [31] Teich, T., Roessler, F., Kretz, D., Franke, S., (2014). "Design of a Prototype Neural Network for Smart Homes and Energy Efficiency," Procedia Engineering, 69, 603-608, DOI: 10.1016/j.proeng.2014.03.032
- [32] *Internet*: Arduino, <http://www.arduino.cc>. [Accessed 8 June 2015].
- [33] Buyukpatpat, H., Das, R., (2015). "Akıllı Ev Sistemleri", Firat Üniversitesi, Teknoloji Fak., Yazılım Mühendisliği, Bitirme Projesi.
- [34] *Internet*: Fritzing, <http://fritzing.org>. [Accessed 8 June 2015].

**Authors**



**Resul Das** received his BS and MSc. in Computer Science from Firat University in 1999, 2002 respectively. He received PhD degree from Electrical and Electronics Engineering Department in same university in 2008. He is an Assoc. Professor at the Department of Software Engineering of Firat University, Turkey. He has authored several paper in international conference proceedings and refereed journals, and has been actively serving as a reviewer for international journals and conferences. His current research interests include Knowledge Discovery, Web Mining, Complex Networks, Computer Networks, Information and Network Security.



**Gurkan Tuna** is an Assoc. Professor at the Department of Computer Programming of Trakya University, Turkey (2006...). He has authored several papers in international conference proceedings and refereed journals, and has been actively serving as a reviewer for international journals and conferences. His current research interests include smart grid, ad hoc and sensor networks, and robotic sensor networks.



**Ayşe Tuna** is a lecturer at School of Foreign Languages, Trakya University, Turkey since 2005. She has authored papers in international conference proceedings, and has been actively serving as a reviewer for international conferences and journals. Her research interests are support services for the elderly and disabled, preservation of cultural heritage, and data management methodologies.